

INSTRUCTION MANUAL - GUIDE D'INSTALLATION

H102

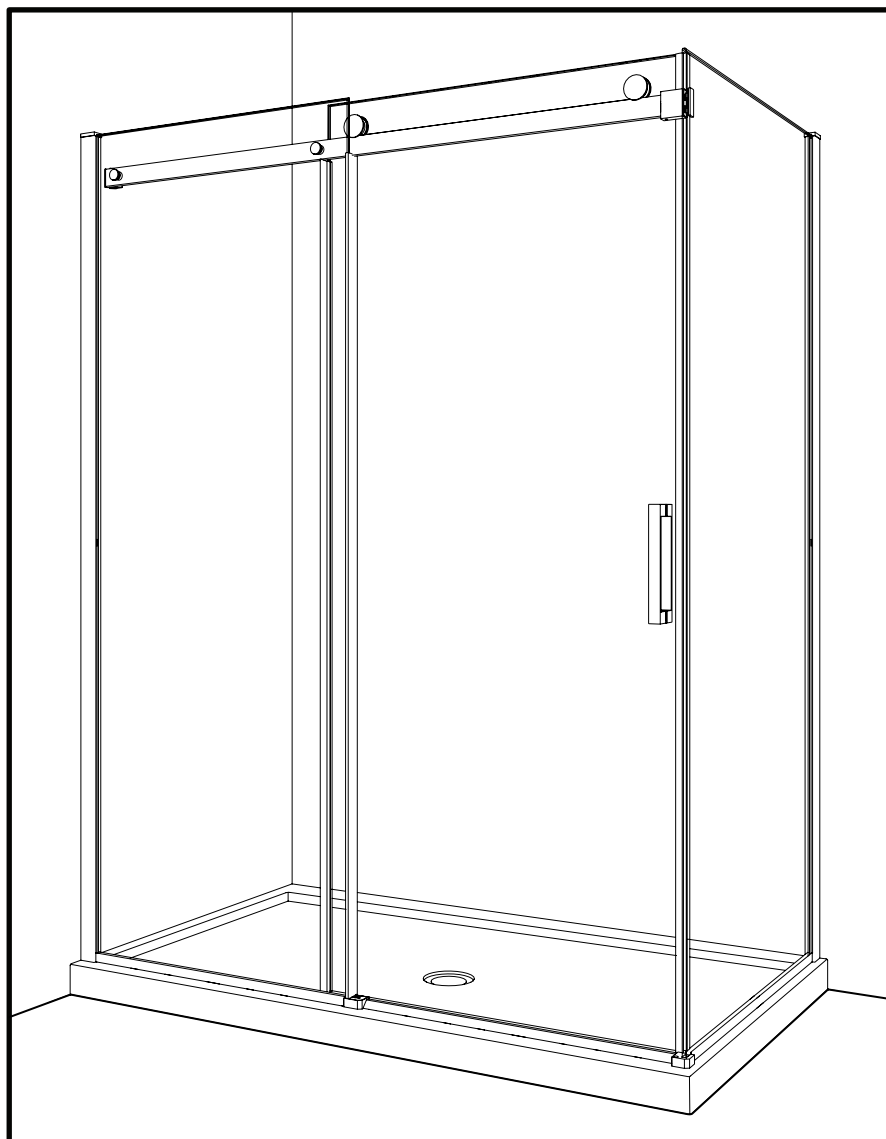

09 / 2019



2 PEOPLE REQUIRED
2 PERSONNES REQUISES

Please keep this manual and product code number for future reference and for ordering replacement parts if necessary.

Veillez conserver ce manuel et le code de produit pour des références futures, et au besoin, la commande de pièces de rechange.

GENERAL INSTRUCTIONS

- Read this manual carefully and completely before proceeding.
- It is recommended that you wear safety glasses at all times during the installation.

INSTALLATION OVER CERAMIC TILES

- If your shower door is to be installed over ceramic tiles, the tiles should lay completely under the wall jamb.
- Silicone should be used to seal the gap where the ceramic tiles meet the fixed panel.

NOTICE

- Caulking: no sealant is required inside the shower, unless otherwise stated.
- Some models are equipped with clear sealing gaskets.

CARE FOR YOUR SHOWER DOOR

- Never use scouring powder pads or sharp instruments on metal pieces or glass panels. An occasional wiping down with a mild soap diluted in water is all that is needed to keep the panels and aluminum parts looking new.
- We recommend wiping the glass panels with a squeegee after each use.

En

INSTRUCTIONS GÉNÉRALES

- Lire attentivement et complètement le manuel d'installation avant de procéder.
- Il est recommandé de porter des lunettes de sécurité en tout temps lors de l'installation.

INSTALLATION SUR LES TUILES EN CÉRAMIQUE

- Si votre porte de douche doit être installée sur une bordure en céramique, le jambage doit reposer complètement sur cette dernière.
- Le calfeutrage doit être appliqué sur le côté extérieur de la douche où le panneau fixe rencontre la bordure en céramique.

NOTE

- Calfeutrage: aucun scellant n'est nécessaire à l'intérieur de la douche.
- Certains modèles sont dotés de joints d'étanchéité clairs.

L'ENTRETIEN DE VOTRE DOUCHE

- Ne jamais utiliser de poudre ou de tampon à récurer, ni d'instrument tranchant sur les parties en métal ou en verre. De temps à autre, il suffit de nettoyer la porte avec une solution d'eau et un détergent doux pour conserver l'aspect neuf des panneaux de verre et du cadre en aluminium.
- Nous recommandons de passer une raclette de douche sur les panneaux de verre après chaque utilisation.

Fr

TOOLS REQUIRED / OUTILS REQUIS

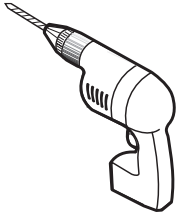

DRILL
PERCEUSE

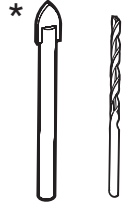

1/4" & 1/8" DRILL BITS
MÈCHE 1/4" & 1/8"



SCREWDRIVER
TOURNEVIS

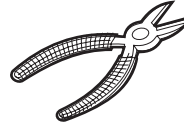

CUTTING PLIERS
PINCE COUPANTE

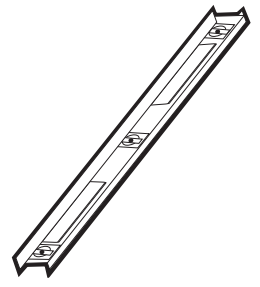

LEVEL
NIVEAU



PENCIL
CRAYON

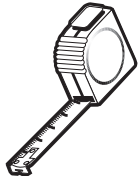

TAPE MEASURE
RUBAN À MESURER

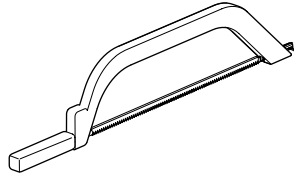

HACKSAW
SCIE À MÉTAUX



SAFETY GLASSES
LUNETTES DE SÉCURITÉ



MALLET
MAILLET



BLOCK
BLOC

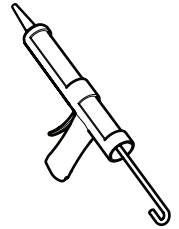

SILICONE
SCÉLLANT

* Use a 1/4" drill bit when drilling into ceramic tiles
* Utiliser une mèche de 1/4" pour percer des tuiles en céramique.

POSSIBLE CONFIGURATIONS / CONFIGURATIONS POSSIBLES

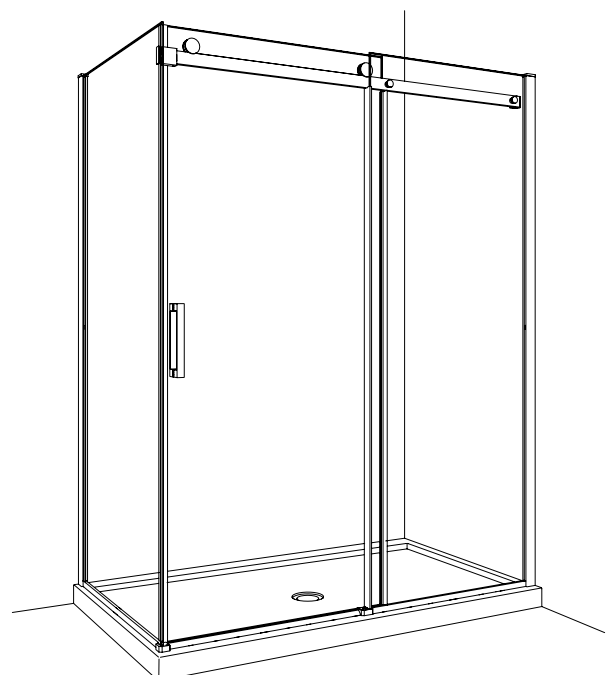
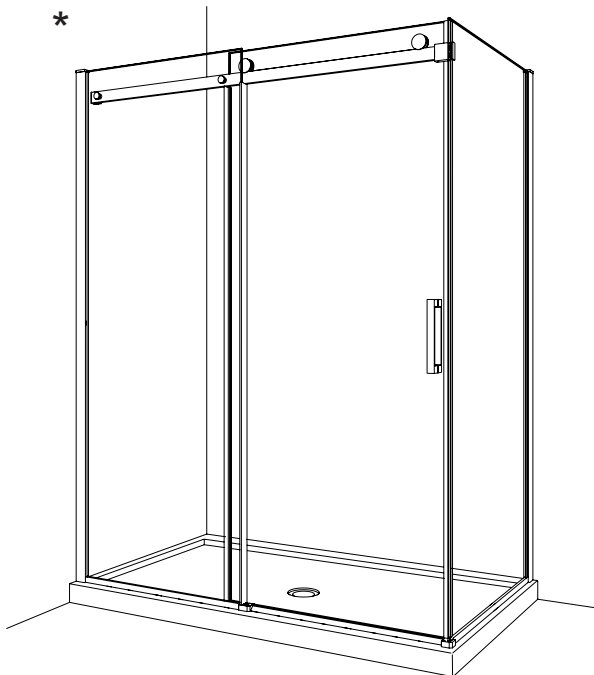

* This configuration illustrated in this manual.
* Cette configuration est illustrée dans ce manuel.

PARTS LISTING / LISTE DES PIÈCES

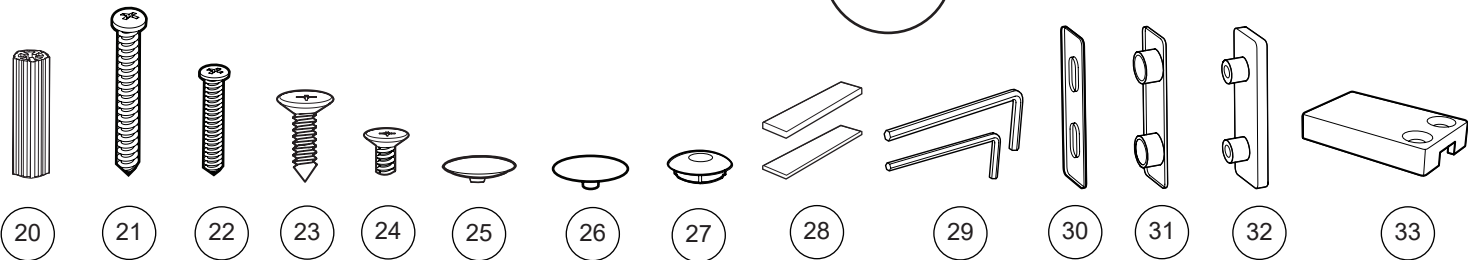
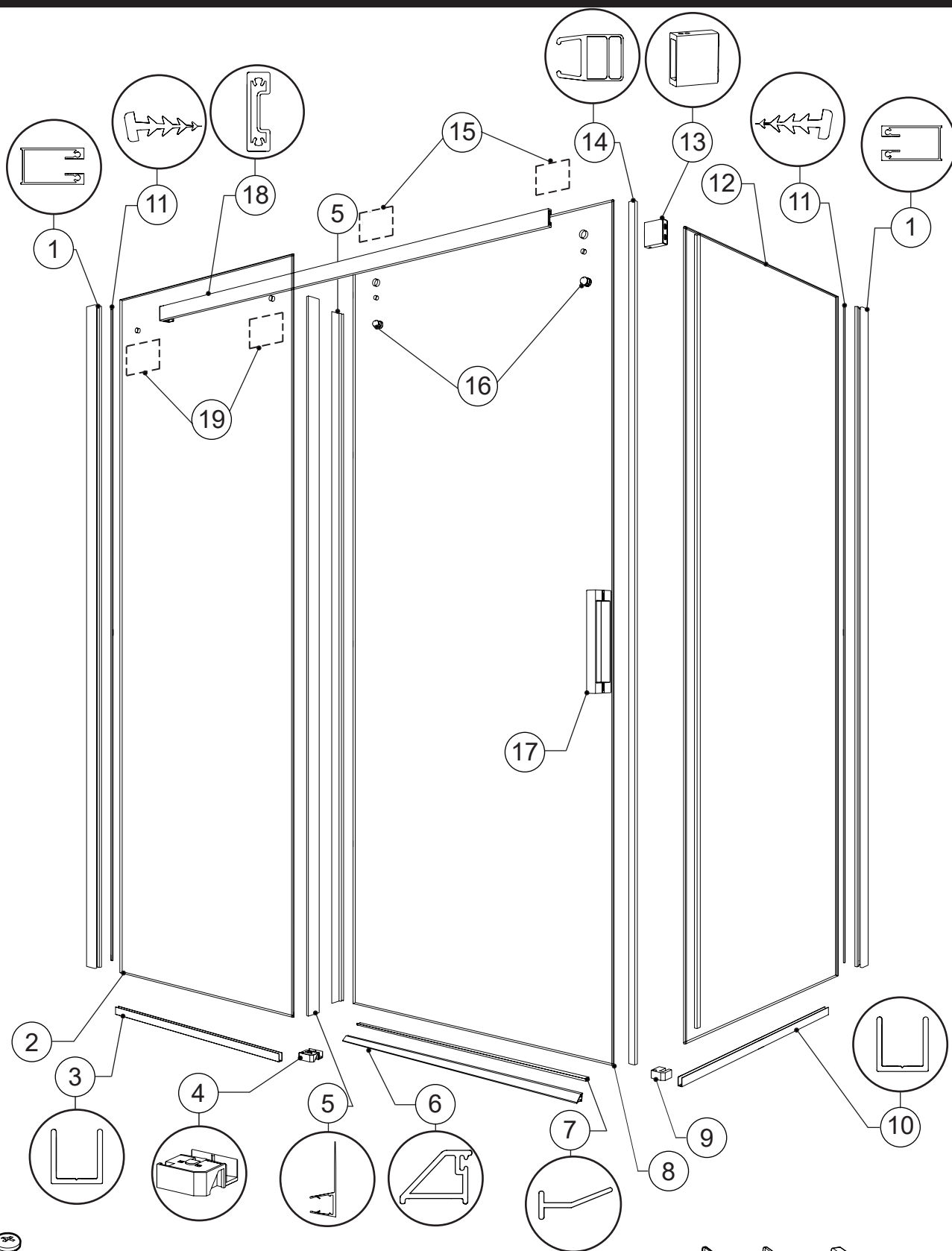

PARTS LISTING / LISTE DES PIÈCES

ITEM	PARTS LISTING / LISTE DES PIÈCES	QTY
1	WALLJAMB / JAMBAGE	1
2	FIXED PANEL / PANNEAU FIXE	1
3	U-CHANNEL FOR FIXED PANEL / PROFILÉ EN «U» POUR PANNEAU FIXE	1
4	BOTTOM GUIDE / GUIDE INFÉRIEUR	1
5	MID GASKET FOR DOOR PANEL AND FIXED PANEL / JOINT LATÉRAL POUR LE PANNEAU DE PORTE ET PANNEAU FIXE	2
6	THRESHOLD / SEUIL	1
7	THRESHOLD GASKET / JOINT DU SEUIL	1
8	DOOR PANEL / PANNEAU DE PORTE	1
9	CORNER ANCHOR / ANCRAGE DU COIN	1
10	U-CHANNEL FOR RETURN PANEL / PROFILÉ EN «U» POUR PANNEAU DE RETOUR	1
11	WALL JAMB GASKET / JOINT DU JAMBAGE	2
12	RETURN PANEL / PANNEAU DE RETOUR	1
13	WALL MOUNT BRACKET / SUPPORT MURAL	1
14	FLAT MAGNETIC SIDE DOOR GASKET / JOINT LATÉRAL MAGNÉTIQUE PLAT DE LA PORTE	1
15	ROLLER (see chart below) / ROULETTE (voir le tableau ci-dessous)	1
16	ANTI-JUMP / ANTI-SAUT	1
17	DOOR HANDLE / POIGNÉE DE PORTE	1
18	RUNNING RAIL / BARRE DE ROULEMENT	1
19	GLASS FASTENER (see chart below) / FIXATION DE VERRE (voir le tableau ci-dessous)	2
ITEM	HARDWARE LISTING / LISTE DE QUINCAILLERIE	QTY
20	WALL PLUG / CHEVILLE	8
21	PAN HEAD SCREW / VIS À TÊTE CYLINDRIQUE	6
22	PAN HEAD SCREW / VIS À TÊTE CYLINDRIQUE	2
23	FLAT HEAD SELF-TAPPING SCREW / VIS AUTO TARAUDAGE À TÊTE PLATE	4
24	FLAT HEAD SELF-TAPPING SCREW / VIS AUTO TARAUDAGE À TÊTE PLATE	2
25	FASTENER CAPS / CAPUCHON DE FIXATION	2
26	ROLLER CAPS / CAPUCHON DE ROULETTE	2
27	CORNER ANCHOR CAP / CAPUCHON D'ANCRAGE DU COIN	1
28	CLEAR SETTING BLOCK (4 X 1/32" & 4 X 1/8") / BLOC À NIVEAU TRANSPARENT (4 X 1/32" & 4 X 1/8")	8
29	HEX KEY / CLÉ HEXAGONALE	2
30	INTERIOR WALL MOUNT BRACKET GASKET / JOINT INTÉRIEUR DU SUPPORT MURAL	1
31	EXTERIOR WALL MOUNT BRACKET GASKET / JOINT EXTÉRIEUR DU SUPPORT MURAL	1
32	WALL MOUNT BRACKET FOR RETURN PANEL / SUPPORT MURAL POUR PANNEAU DE RETOUR	1
33	WALLJAMB CAP / CAPUCHON DU JAMBAGE	2

15

ROLLER OPTIONS / SÉLECTION DES ROULETTE

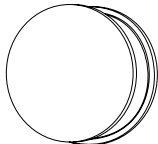
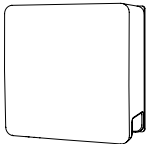
A	B
	

19

FASTENER OPTIONS / SÉLECTION DES FIXATION

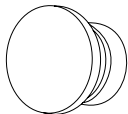
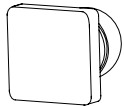
C	D
	

1

MARK THE PLACEMENT AREA ON THE BASE / MARQUER LA ZONE DE POSITIONNEMENT SUR LA BASE

MODEL / MODÈLE	FRONT (DIM A) / DEVANT (DIM A)	
	MIN	MAX
24832	46"	48"
24836		
26032	56"	60"
26036		



The installation shown is based on plumb finished walls and a levelled base. If these conditions are not met, please adjust accordingly.

L'installation illustrée est basée sur des murs finis d'aplomb et une base de douche nivelée. Si ces conditions ne sont pas présentes, ajuster en conséquence.

MODEL / MODÈLE	SIDE (DIM B) / CÔTÉ (DIM B)	
	MIN	MAX
24832	29 5/16"	29 13/16"
26032		
24836	33 5/16"	33 13/16"
26036		

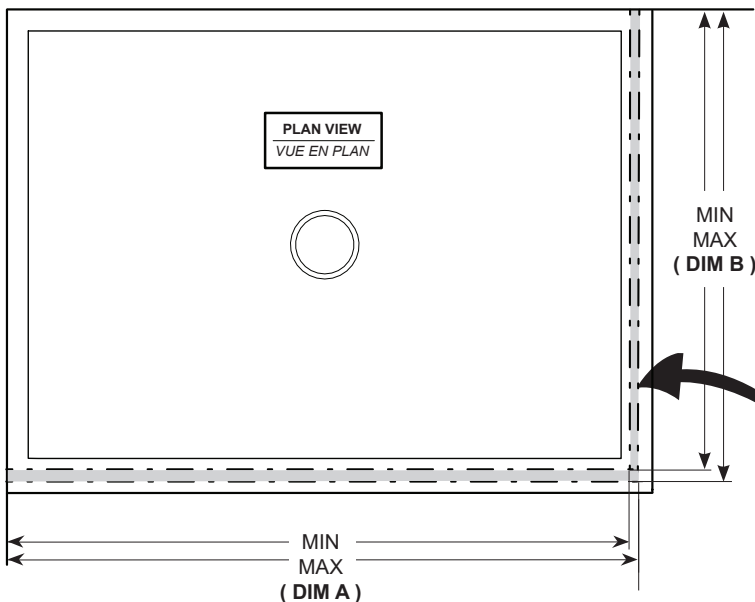
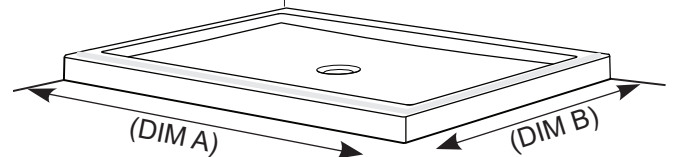

RECOMMENDED AREA FOR SHOWER DOOR INSTALLATION.

ZONE RECOMMANDÉE POUR L'INSTALLATION DE LA PORTE DE DOUCHE.

2

DETERMINE THE CENTERLINE FOR FIXED PANEL LOCATION USING THE BOTTOM GUIDE FOR REFERENCE
MARQUER LA LIGNE DU CENTRE DU PANNEAU FIXE SUR LA BASE EN UTILISANT LE GUIDE INFÉRIEUR COMME RÉFÉRENCE



THE POSITIONING OF THE BOTTOM GUIDE IS CARRIED OUT ON FLEURCO BASES. FOR NON-FLEURCO BASES REFER TO THE CHARTS ON PAGE 6 TO PROPERLY PLACE THE BOTTOM GUIDE

LE PLACEMENT DU GUIDE DE BAS EST EFFECTUÉ SUR DES BASES FLEURCO. POUR LE POSITIONNEMENT DU GUIDE DE BAS SUR DES BASES N'APPARTENANT PAS À FLEURCO, SE RÉFÉRER AUX TABLEAUX SUR LA PAGE 6



Do not install the bottom guide (4) in this step.

Ne pas installer le guide intérieur (4) dans cette étape

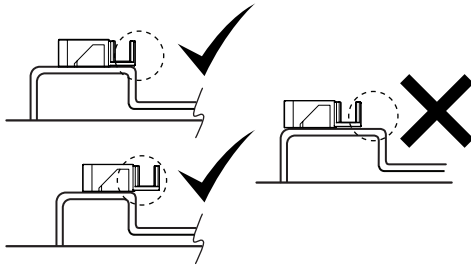

SIDE VIEW / VUE LATÉRALE

The bottom guide can hang off the base as long as it can be well fastened and is towards the inside of the shower.

Le guide inférieur peut dépasser la base en autant qu'il puisse être bien fixé et vers l'intérieur de la douche.

Edge of base threshold (interior shower side)

Côté intérieur de la douche (Bord inférieur du seuil de base)

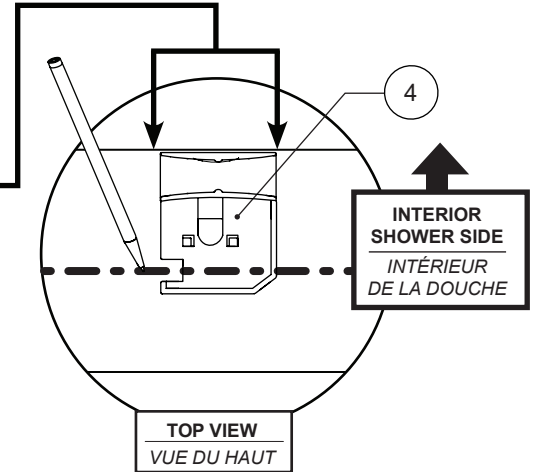

TOP VIEW
VUE DU HAUT

INTERIOR SHOWER SIDE
INTÉRIEUR DE LA DOUCHE

3

DETERMINE THE CENTERLINE FOR RETURN LOCATION
MARQUER LA LIGNE DU CENTRE DU PANNEAU DE RETOUR SUR LA BASE

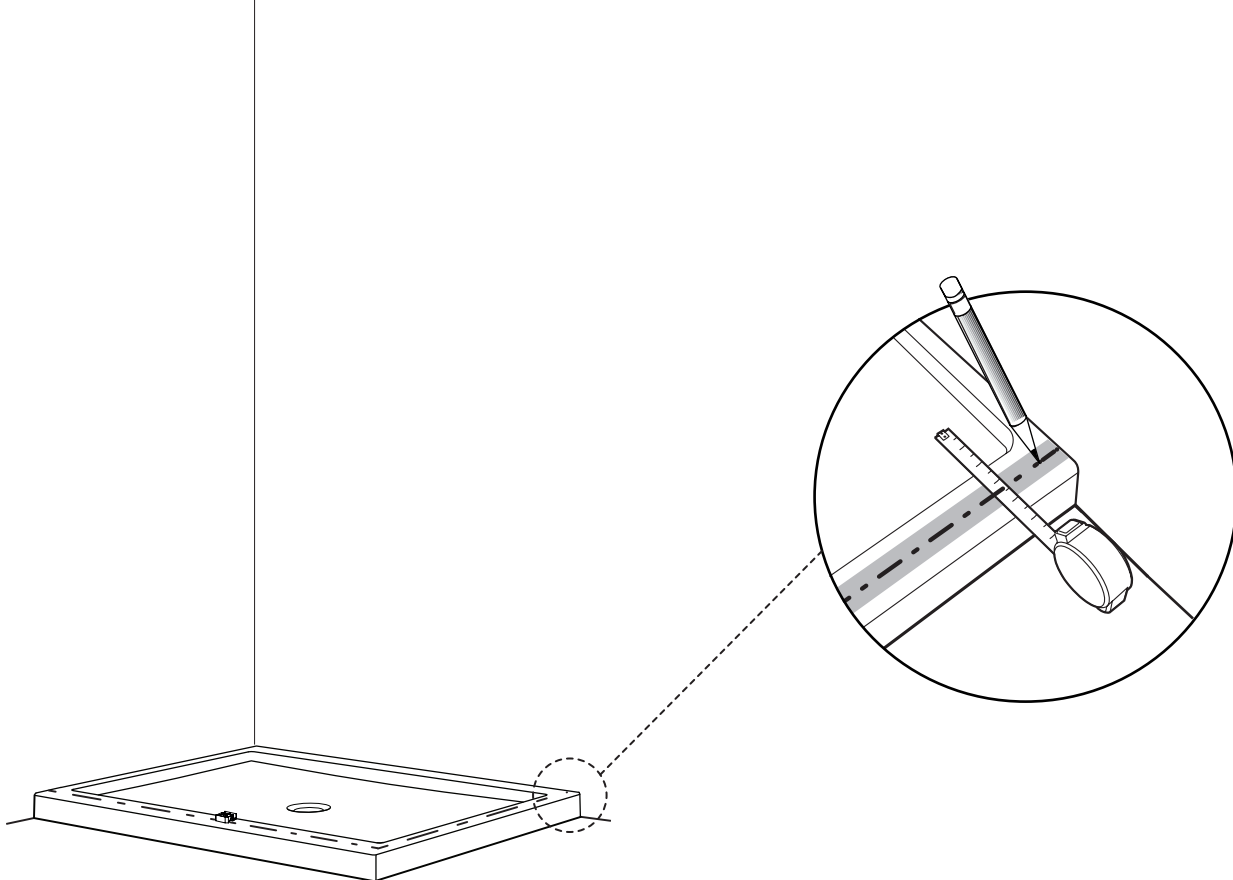

4

CENTER THE WALL JAMBS / CENTRER LES JAMBAGES

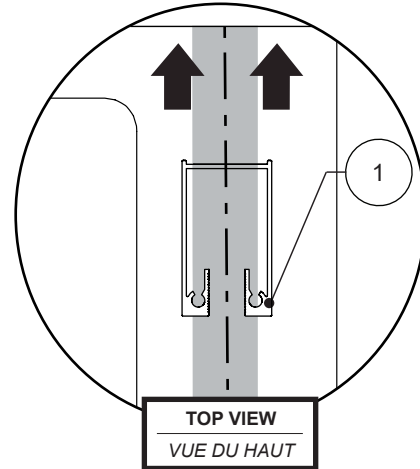
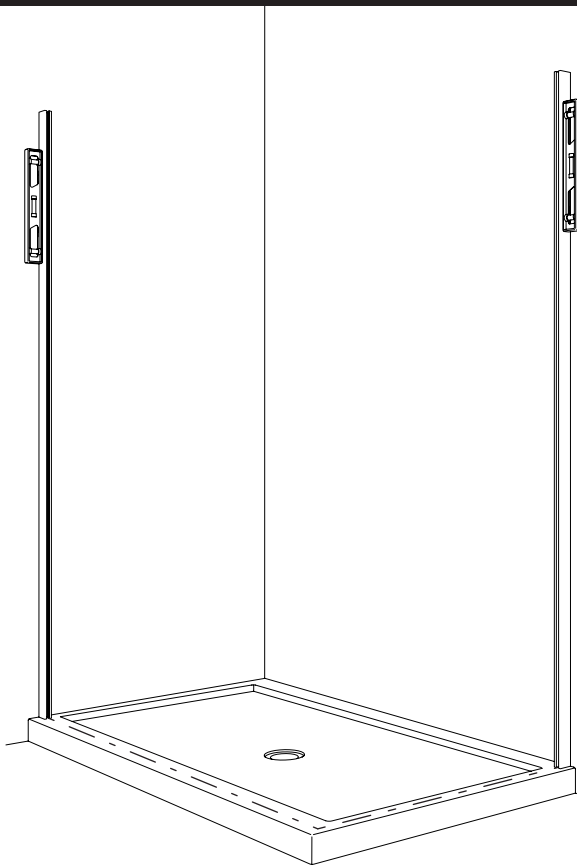

5

**LEVEL AND MARK THE LOCATION OF THE WALL JAMB HOLES ON THE WALL
NIVELER ET MARQUER L'EMPLACEMENT DES TROUS DU JAMBAGE SUR LE MUR**

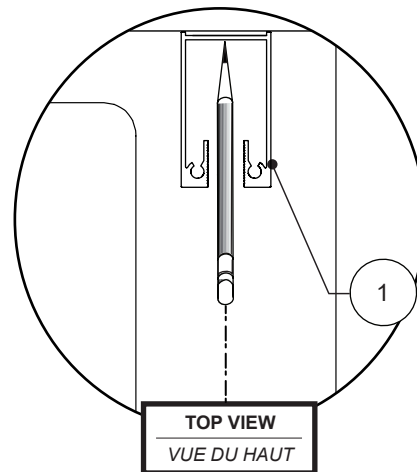
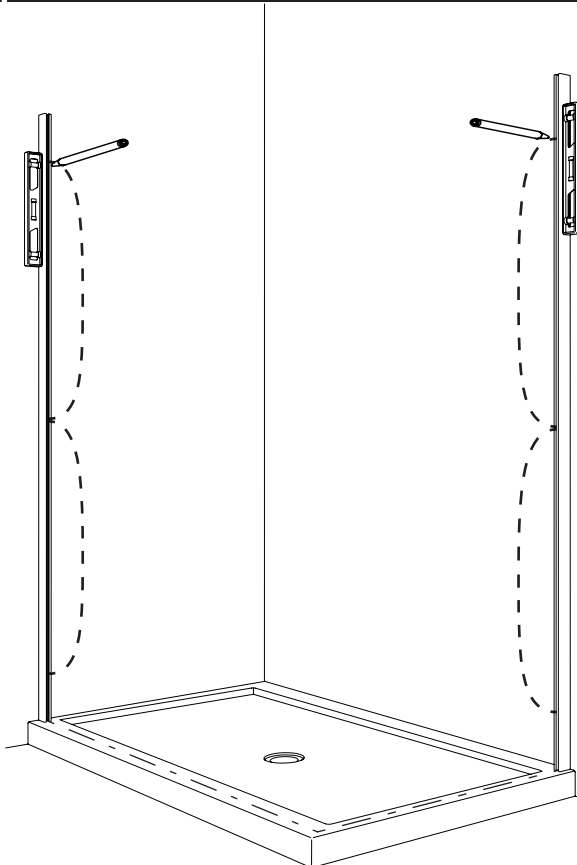

6

DRILL, APPLY SILICONE & INSERT THE WALL PLUGS
PERCER, APPLIQUER DU SILICONE ET INSÉRER LES CHEVILLES

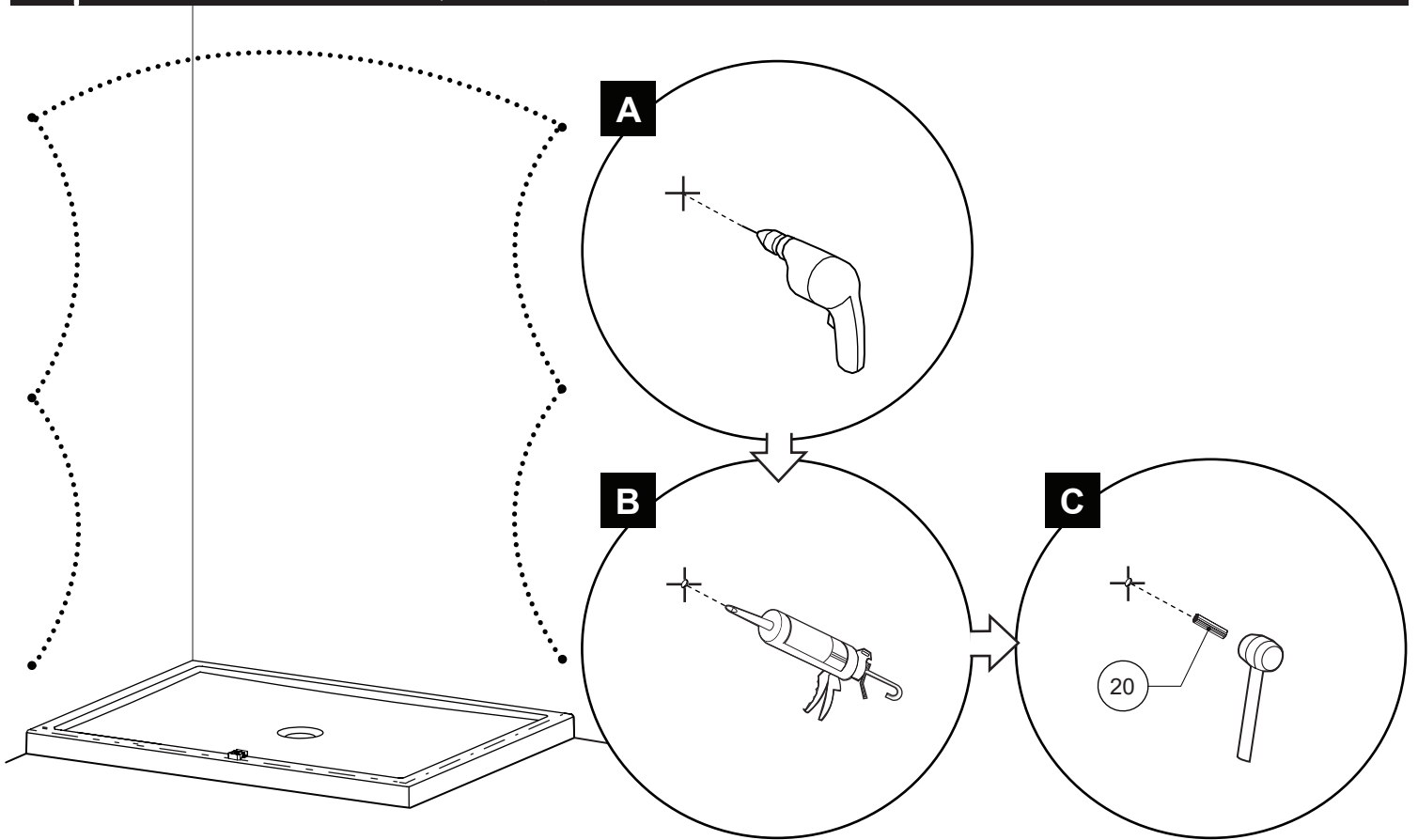

7

SILICONE AND SECURE THE WALL JAMBS
CALFEUTRER ET SÉCURISER LES JAMBAGES

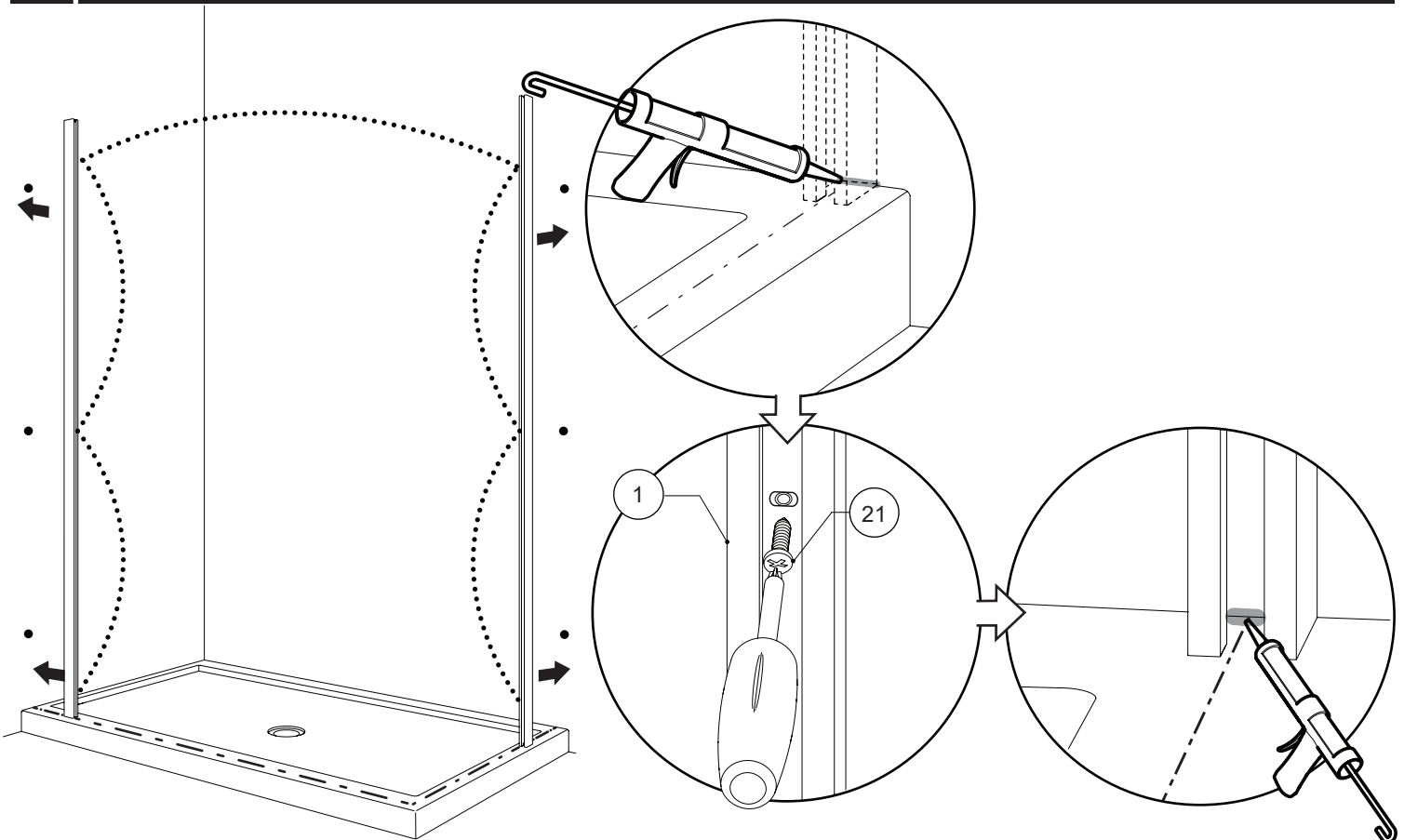

8

TEMPORARILY PLACE THE U-CHANNEL FOR FIXED PANEL AND BOTTOM GUIDE
PLACER LE PROFILÉ EN «U» POUR LE PANNEAU FIXE ET LE GUIDE TEMPORAIREMENT

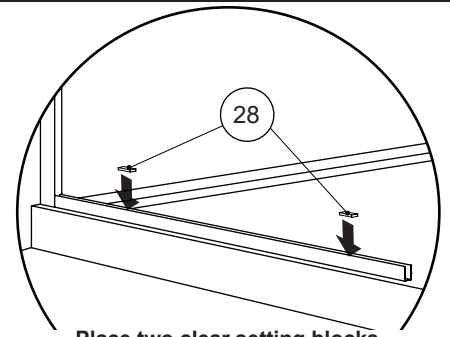
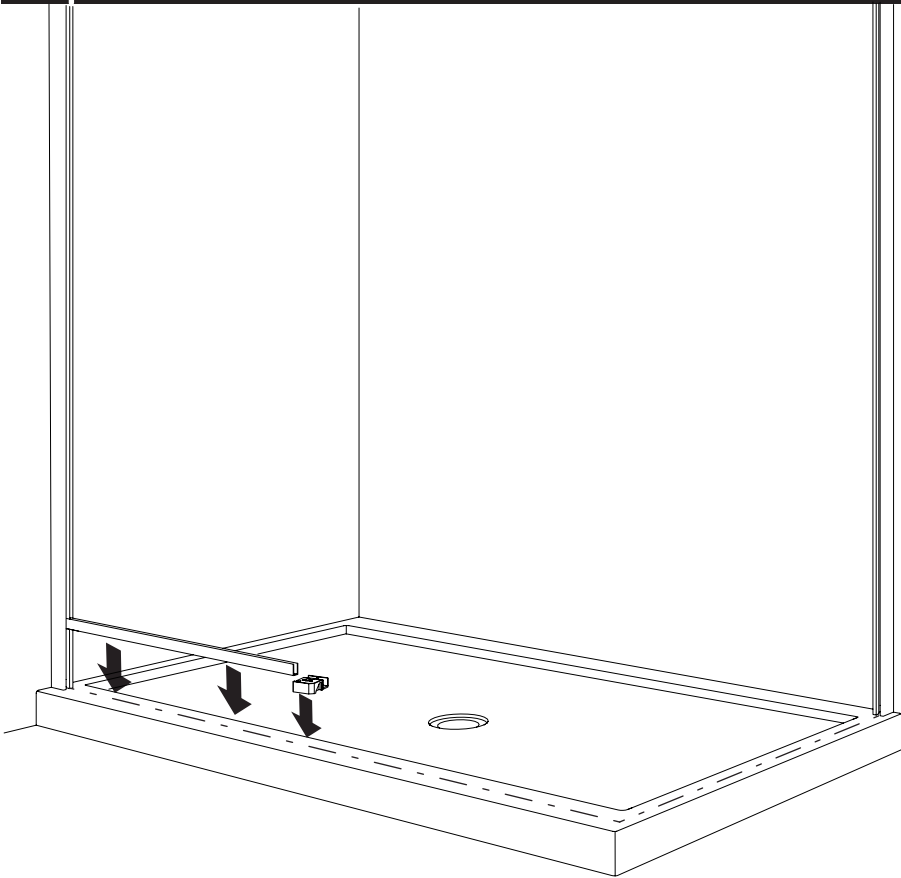

**Place two clear setting blocks
1/8" in the "U"-channel.**
*Placer deux blocs de niveau transparents
1/8" de dans le profilé en «U».*

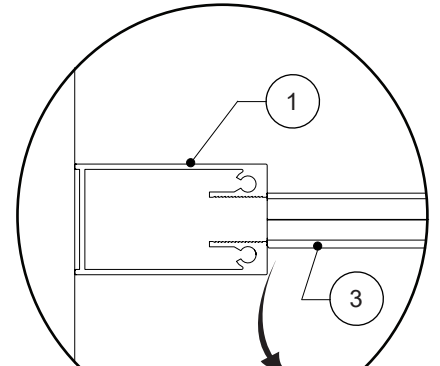

**Make sure the U-channel is flush
with exterior of walljamb**
*S'assurer que le profilé en «U» est aligné
avec l'extérieur du jambage*

9

TEMPORARILY PLACE THE CORNER ANCHOR
PLACER L' ANCRAGE DU COIN TEMPORAIREMENT

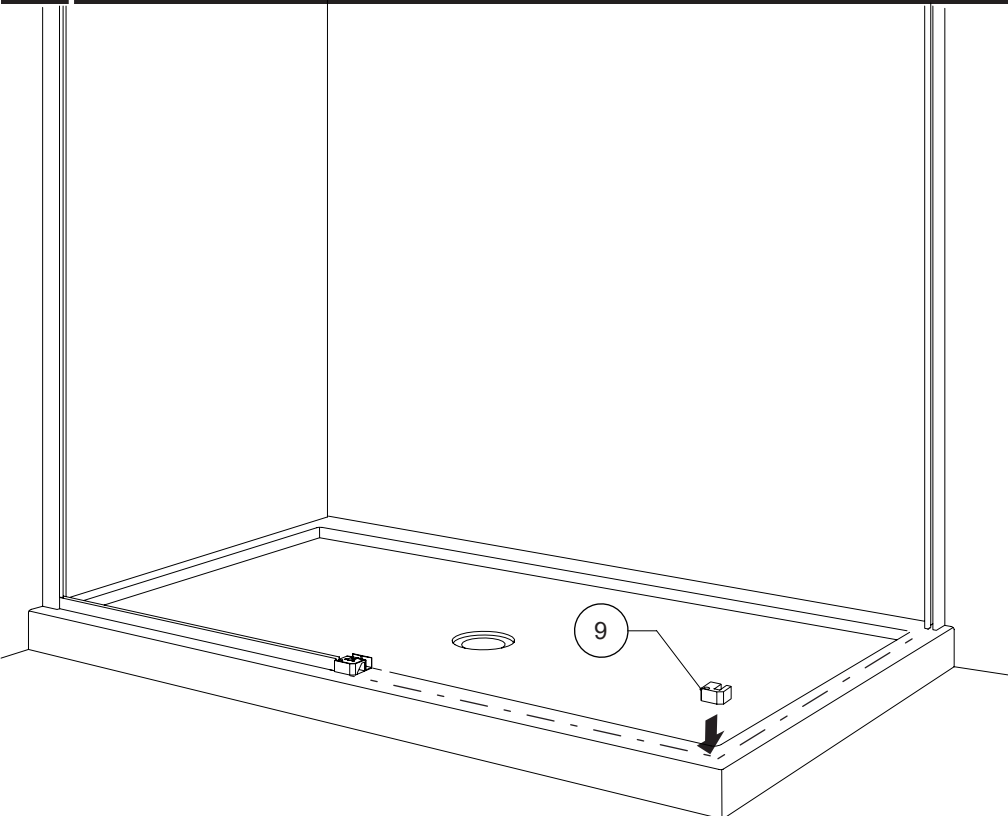

10 DETERMINE THE LOCATION OF CORNER ANCHOR BY USING THE BOTTOM GUIDE FOR REFERENCE
MARQUER LA POSITION DE L'ANCRAGE DU COIN EN UTILISANT LE GUIDE INFÉRIEUR COMME RÉFÉRENCE

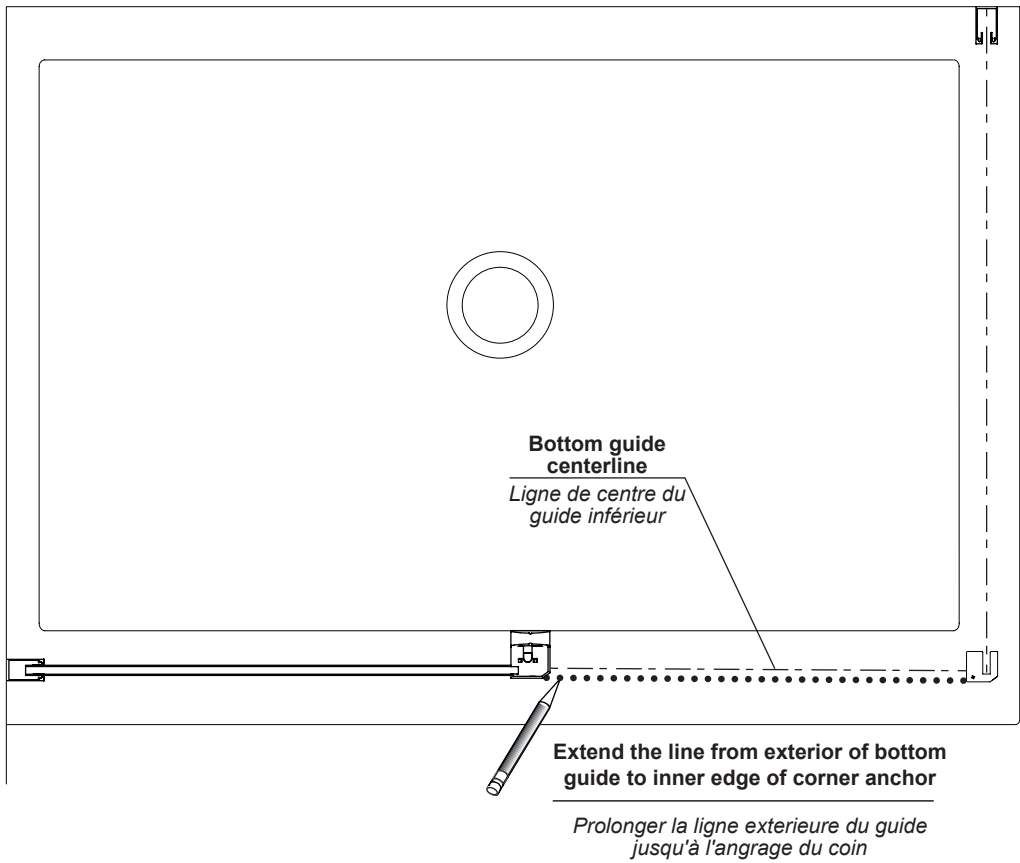

11 MARK U-CHANNEL FOR THE RETURN PANEL
MARQUER LE PROFILÉ EN «U» POUR LE PANNEAU DE RETOUR

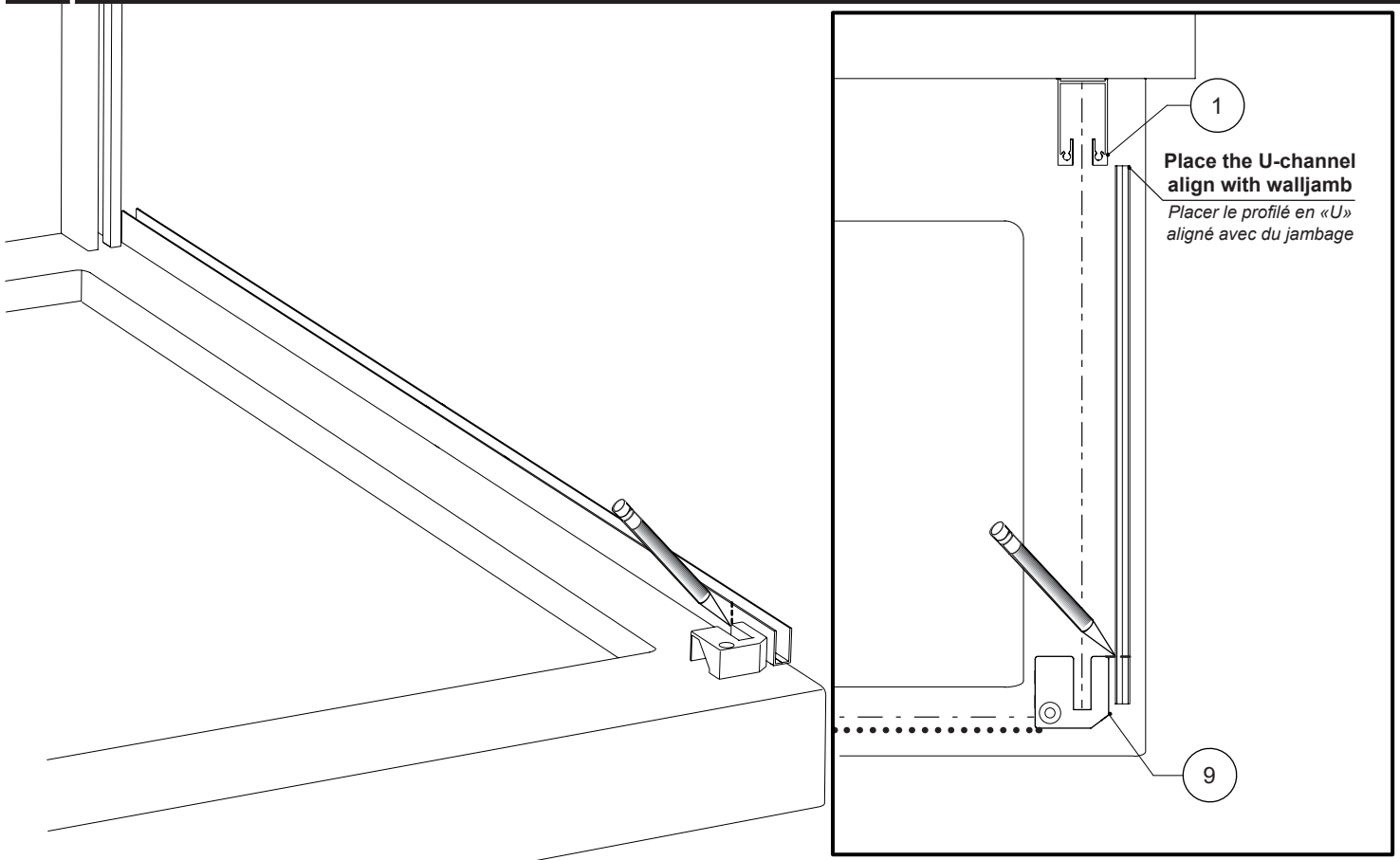

12

CUT THE U-CHANNEL FOR THE RETURN PANEL
COUPER LE PROFILÉ EN «U» POUR LE PANNEAU DE RETOUR

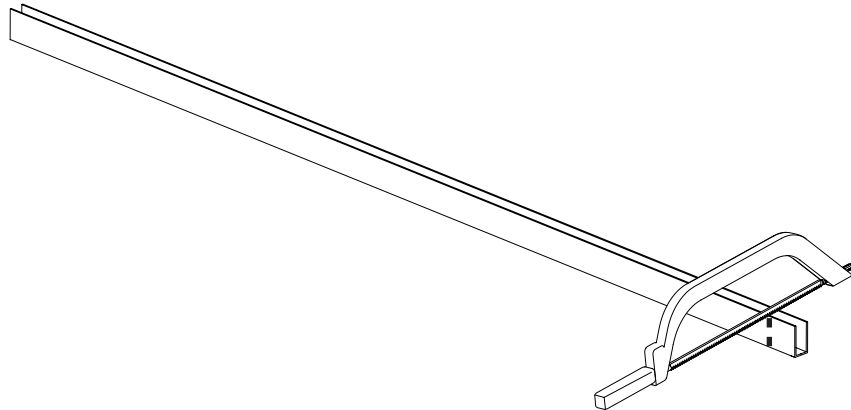

13

TEMPORARILY PLACE THE U-CHANNEL AND RETURN PANEL
PLACER LE PROFILÉ EN «U» ET LE PANNEAU DE RETOUR TEMPORAIREMENT

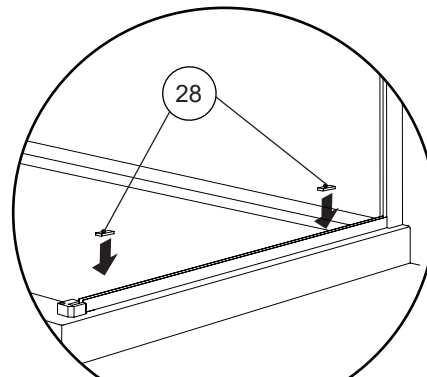
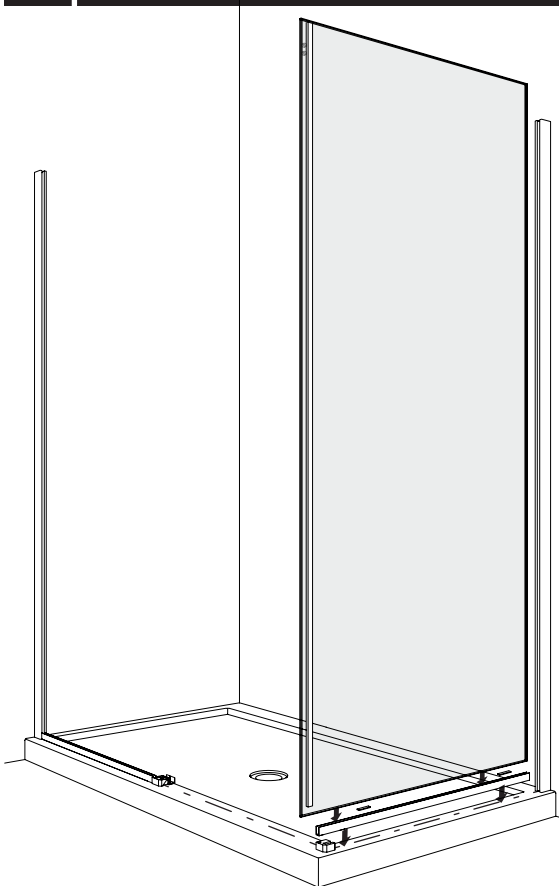

Do not forget the setting blocks.

Ne pas oublier les blocs de niveau transparents.

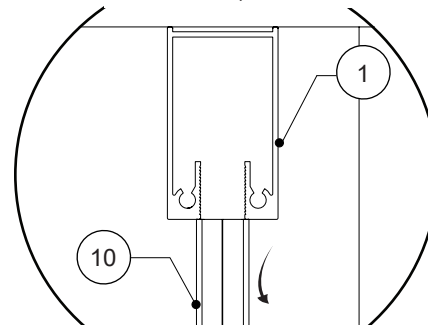

Make sure the U-channel is flush with exterior of wall jamb

S'assurer que le profilé en «U» est aligné avec l'extérieur du jambage

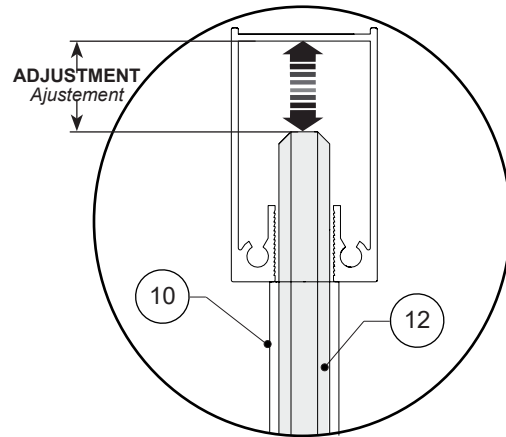
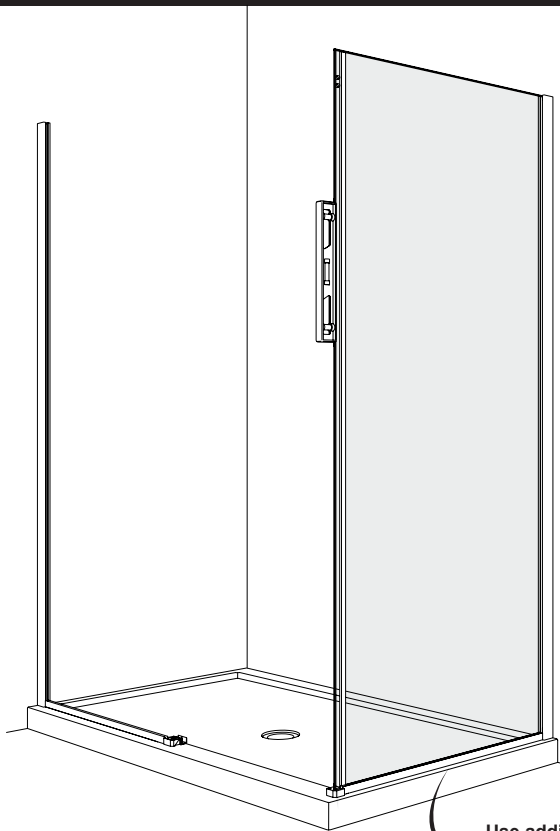

Use additional setting blocks to adjust if necessary.
Utiliser des blocs de niveau transparents supplémentaires pour ajuster si nécessaire.

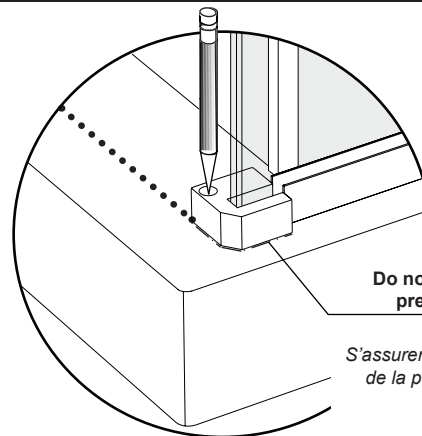
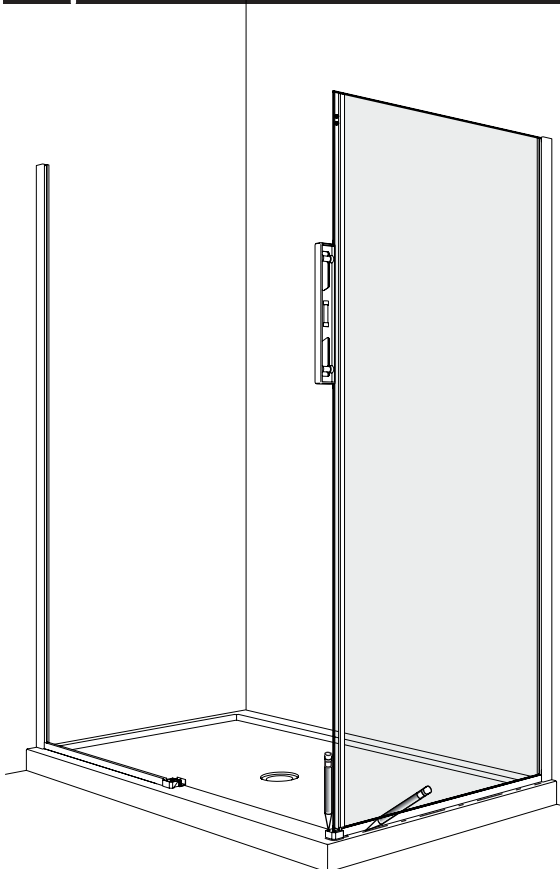

Refer to step 11
 Do not move the corner anchor from previously determined position

Référez à l'étape 11
 S'assurer que l'ancrage de coin ne bouge pas de la position déterminée précédemment

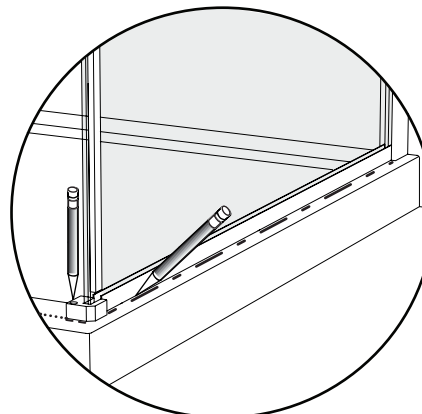

16

REMOVE THE BOTTOM GUIDE, CORNER THRESHOLD, U-CHANNELS AND RETURN PANEL
ENLEVER LE GUIDE INFÉRIEUR, L'ANCRAGE DU SEUIL DE COIN, LES PROFILÉS EN «U» ET LE PANNEAU DE RETOUR

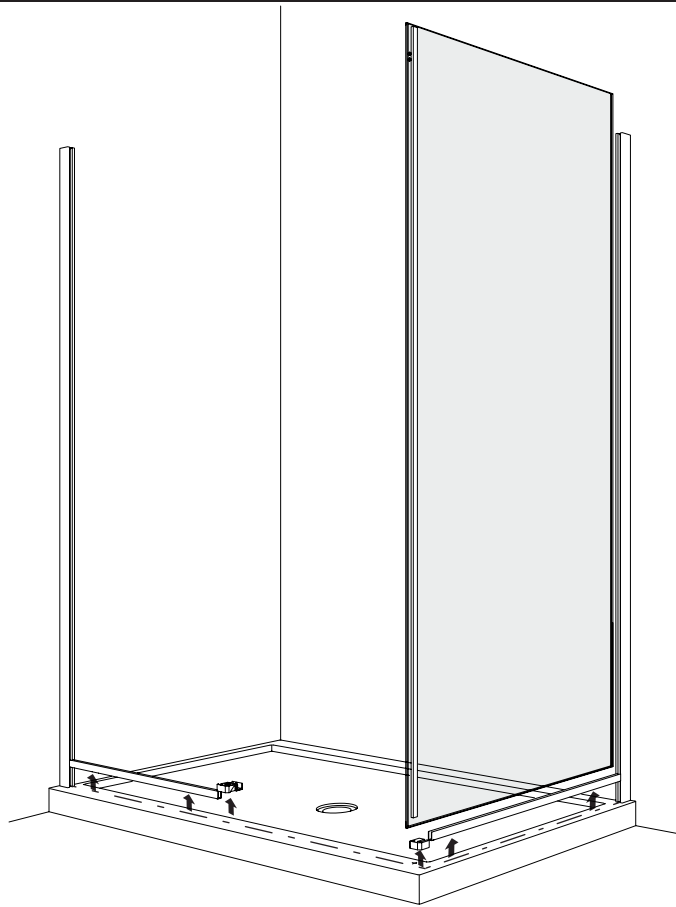
**17**

INSTALL THE U-CHANNEL FOR RETURN PANEL
INSTALLER LE PROFILÉ EN «U» POUR LE PANNEAU DE RETOUR

A

Wipe the base with a clean cloth before installing the U-channel.

Essuyer la base avec un chiffon propre avant d'installer le profilé en «U».

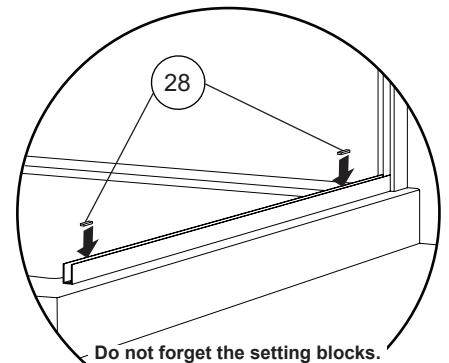
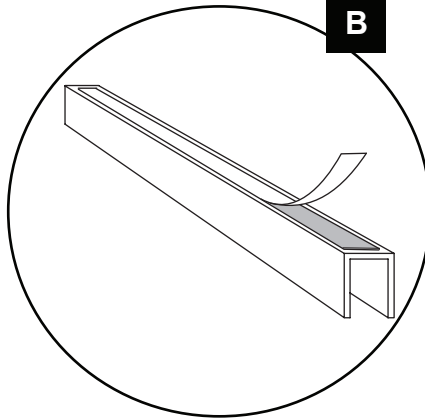
B

Do not forget the setting blocks.

Ne pas oublier les blocs de niveau transparents.

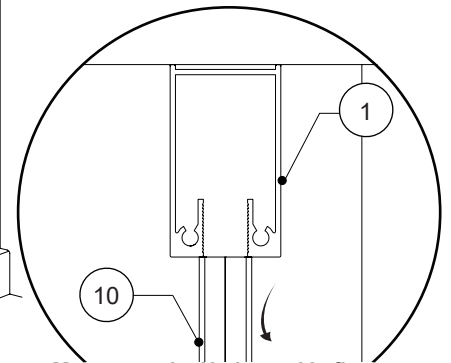

Make sure the U-channel is flush with exterior of walljamb

S'assurer que le profilé en «U» est aligné avec l'extérieur du jambage

18

INSTALL THE CORNER THRESHOLD ANCHOR / INSTALLER L'ANCRAGE DE SEUIL DE COIN

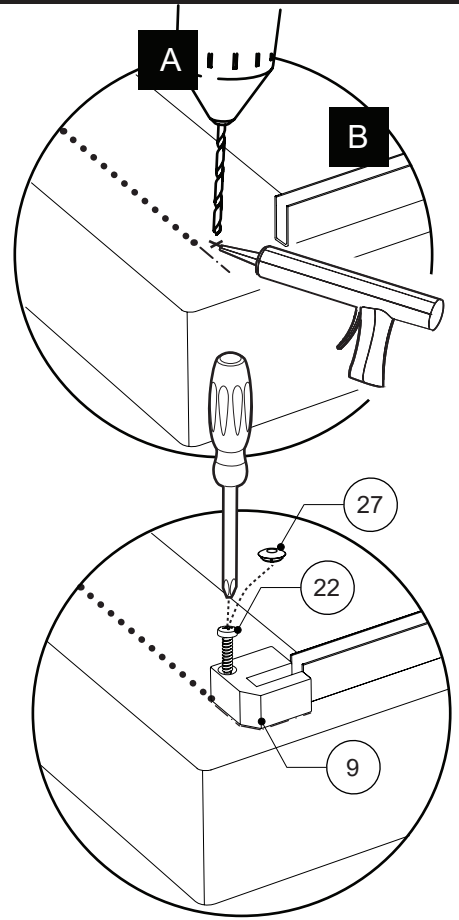
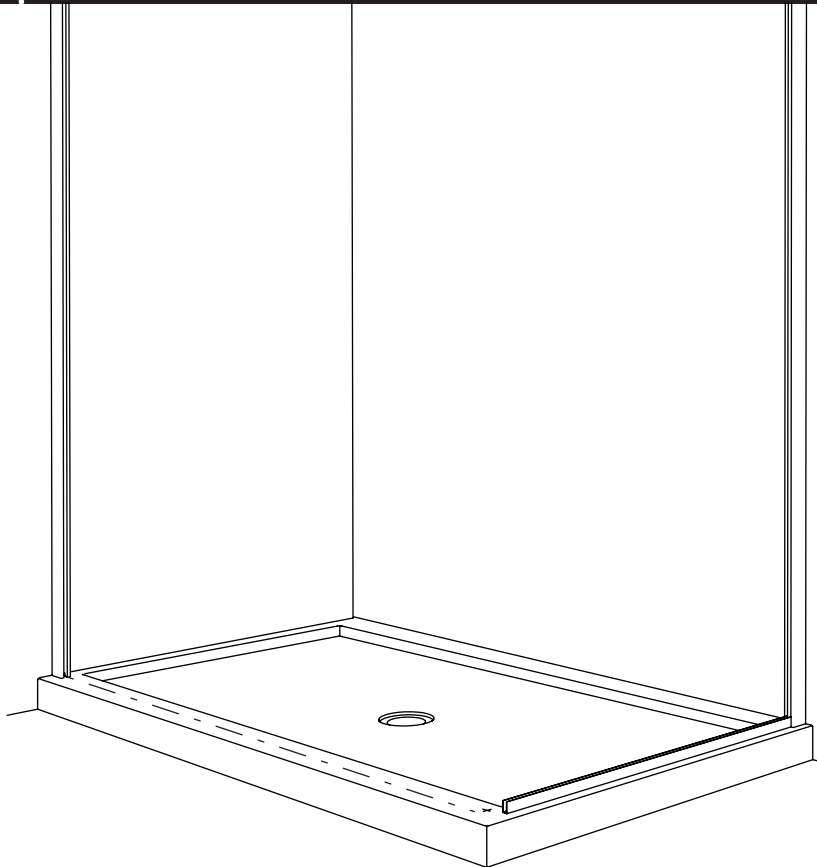

19

INSTALL THE RETURN PANEL AND LEVEL / INSTALLER LE PANNEAU DE RETOUR ET NIVELER

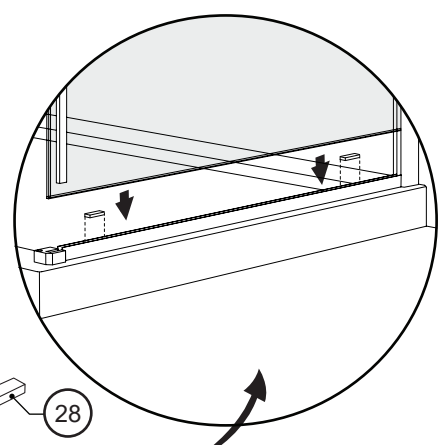
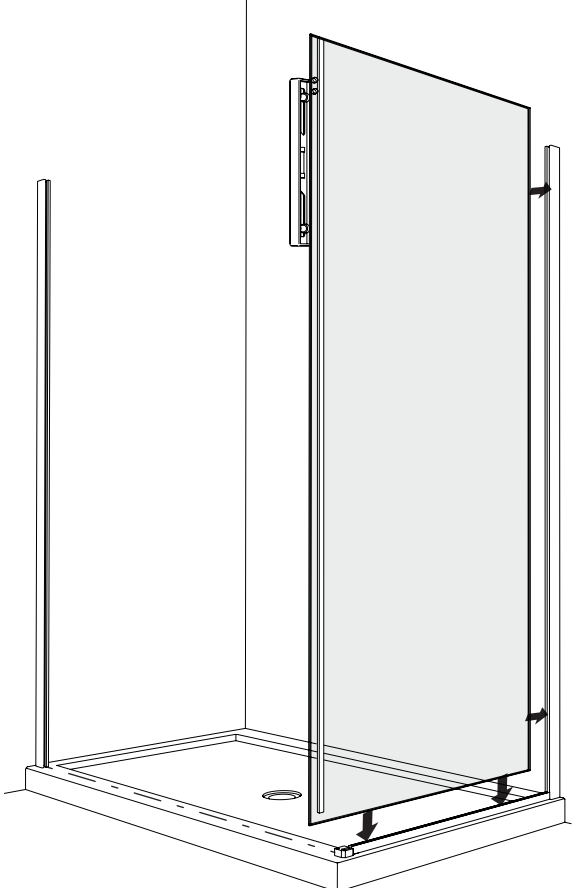

Do not forget the setting blocks.
Ne pas oublier les blocs de niveau transparents.

20

INSTALL THE WALL JAMB GASKET / INSTALLER LE JOINT LATÉRAL DU JAMBAGE

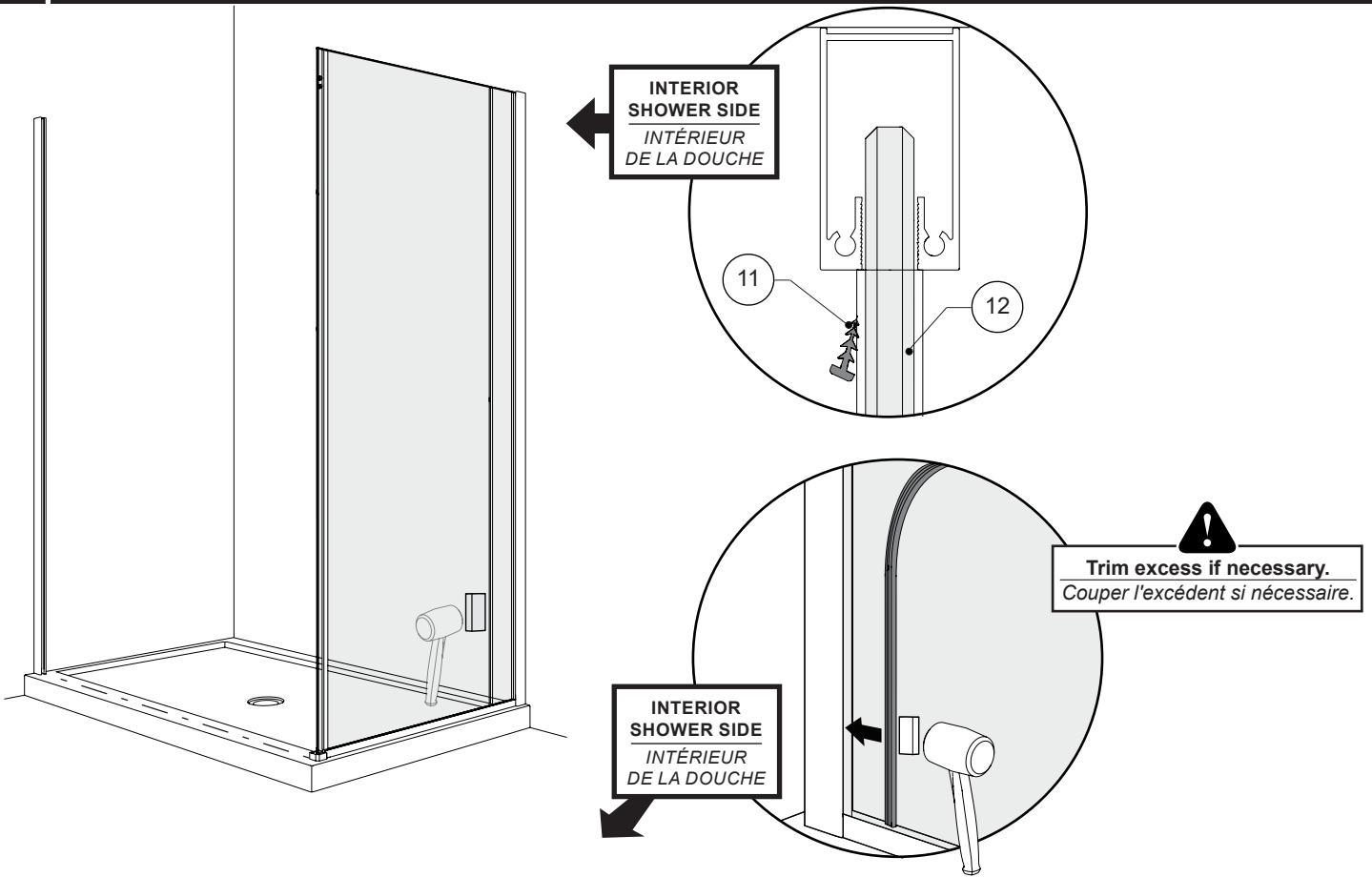

21

LEVEL THE RETURN PANEL / NIVELER LE PANNEAU DE RETOUR

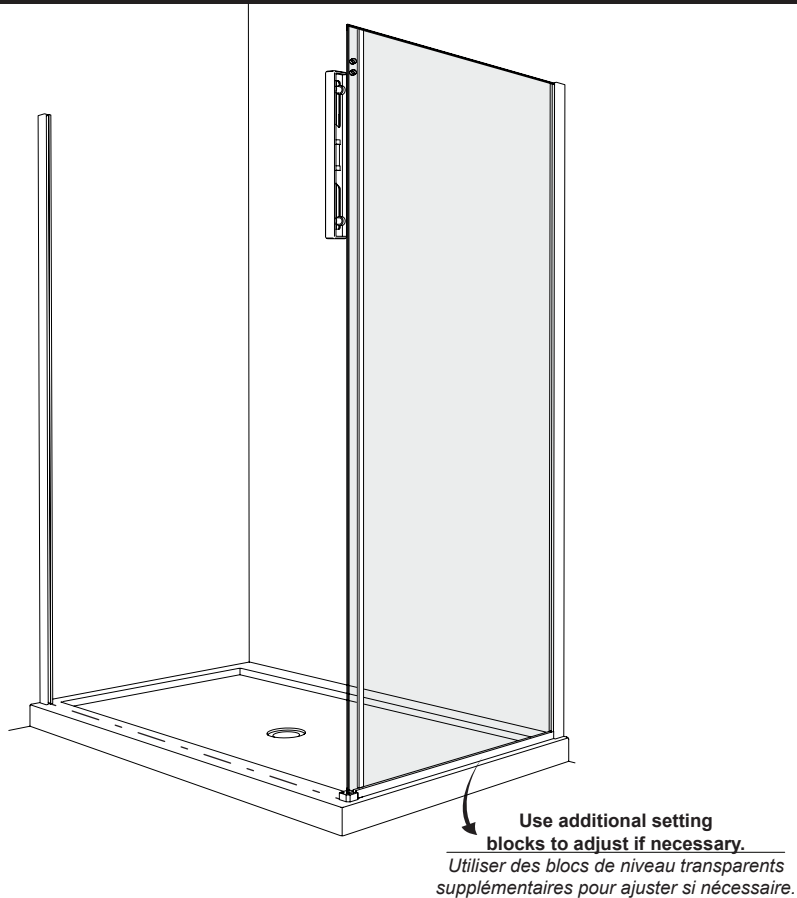

22

INSTALL THE RETURN PANEL WALL MOUNT BRACKET
INSTALLER LE SUPPORT MURAL DE VERRE POUR PANNEAU DE RETOUR

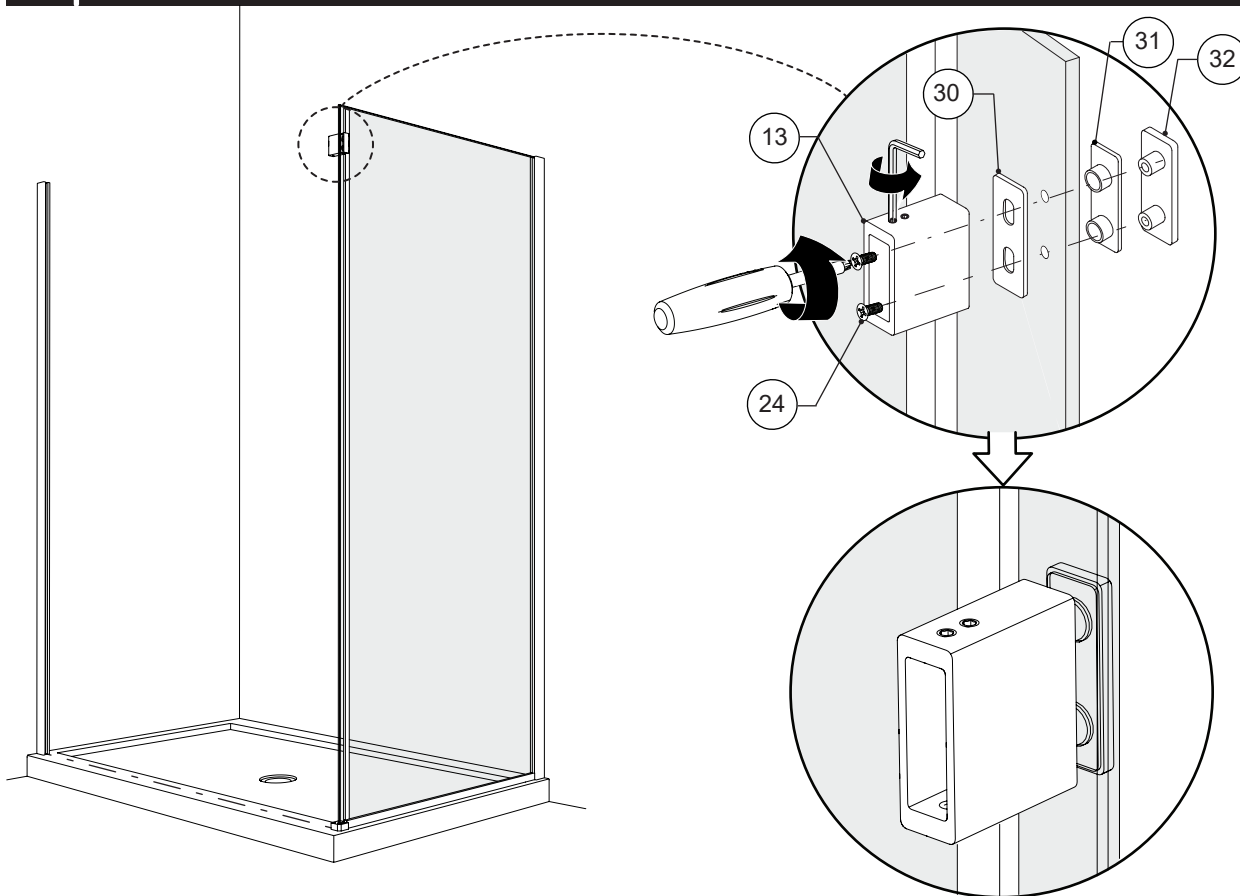

23

INSTALL THE ROLLERS ONTO THE DOOR
INSTALLER LES ROULETTES SUR LA PORTE

* **FOR SQUARE ROLLERS INSTALLATION ,REFER TO END OF THE MANUAL**
POUR INSTALLATION DES ROULETTE CARRÉES ,RÉFÉRER À LA FIN DU MANUEL

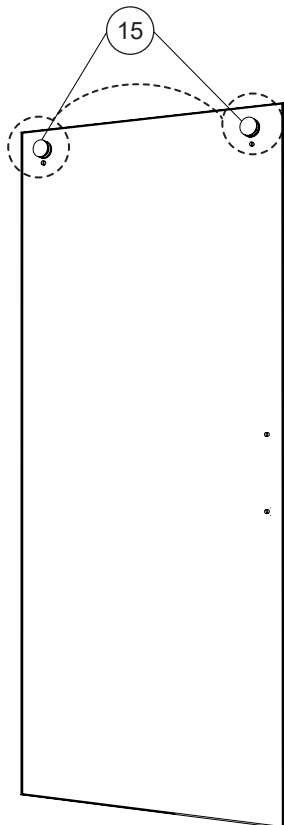

Do not place the roller cap in this step

Ne pas placer le capuchon des roulettes dans cette étape

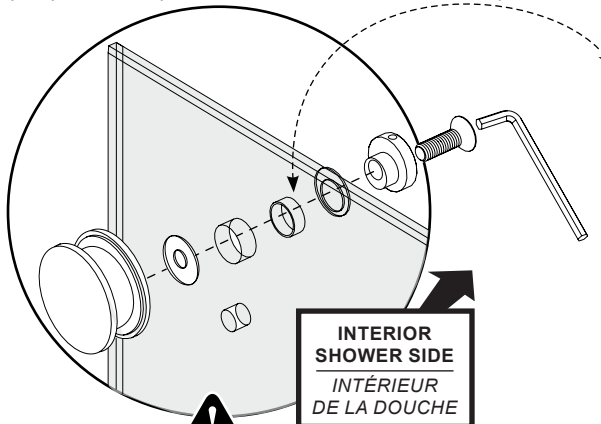

**INTERIOR
SHOWER SIDE**
**INTÉRIEUR
DE LA DOUCHE**

Use screws with threadlocker coating provided in the bag

Utiliser les vis recouvertes de produit bloquant pour filetage incluses dans le sachet



ENSURE THAT THE SLIDING DOOR IS FLUSH AGAINST THE RETURN PANEL. ADJUST THE ROLLER'S ECCENTRIC WASHER IF NECESSARY.

ASSURER QUE LE PANNEAU DE PORTE COULISSANTE EST D'APLOMB CONTRE LE PANNEAU DE RETOUR. AJUSTER LA RONDELLE EXCENTRIQUE DE LA ROULETTE SI NÉCESSAIRE.

A Door panel at its lowest position
 Panneau de porte à la position la plus basse

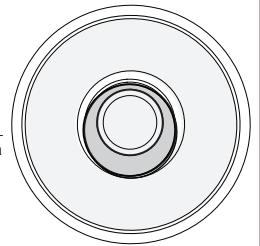

B Door panel at its highest position
 Panneau de porte à la position la plus haute

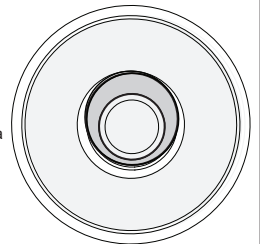

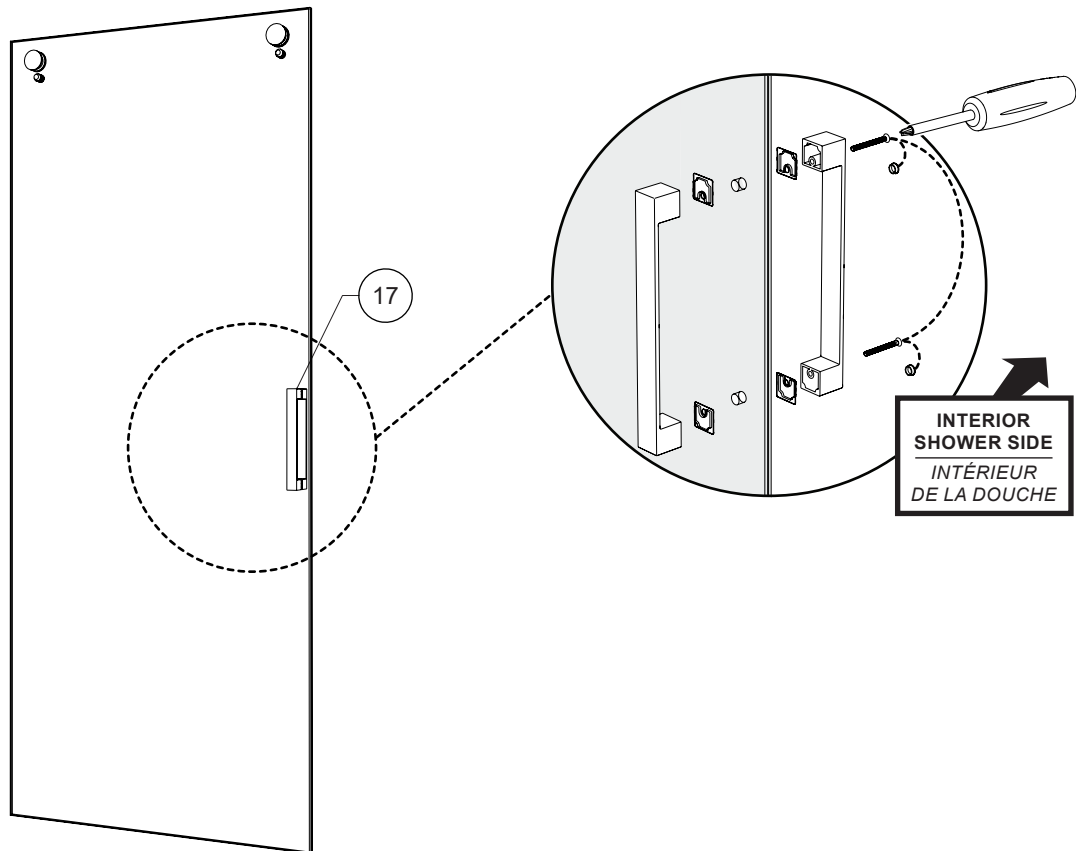
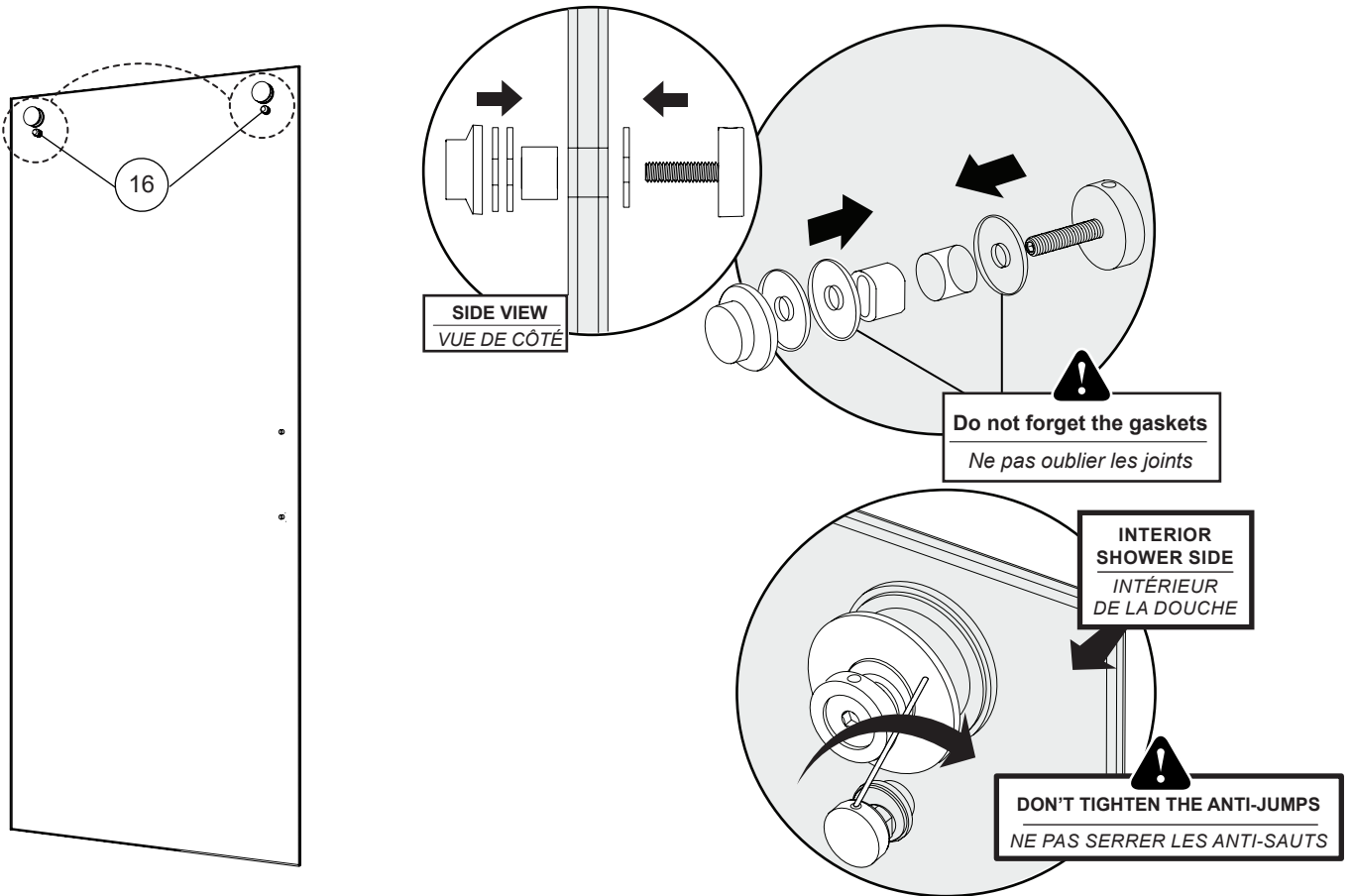

26 INSTALL THE MAGNETIC SIDE DOOR GASKET / INSTALLER LE JOINT LATÉRAL MAGNÉTIQUE DE LA PORTE

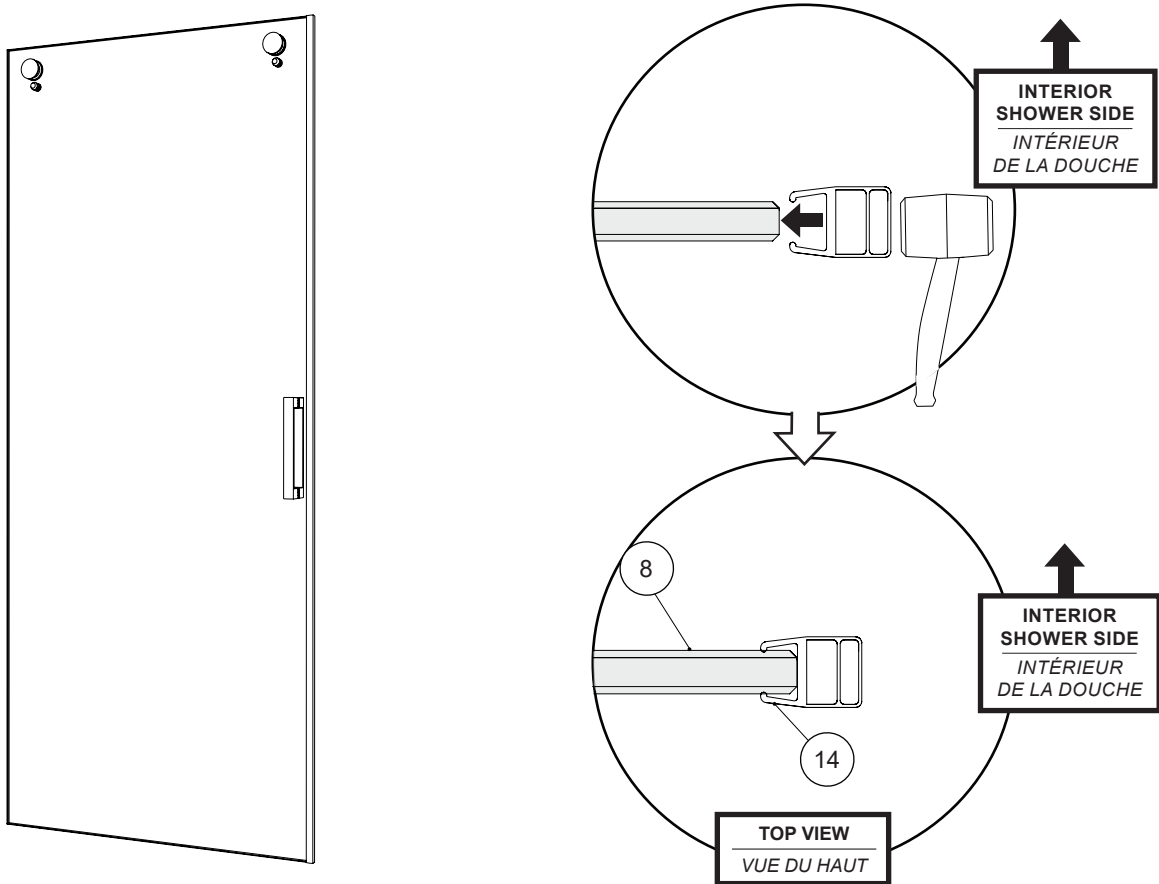

27 PLACE THE DOOR INSIDE THE SHOWER / PLACER LA PORTE À L'INTÉRIEUR DE LA DOUCHE

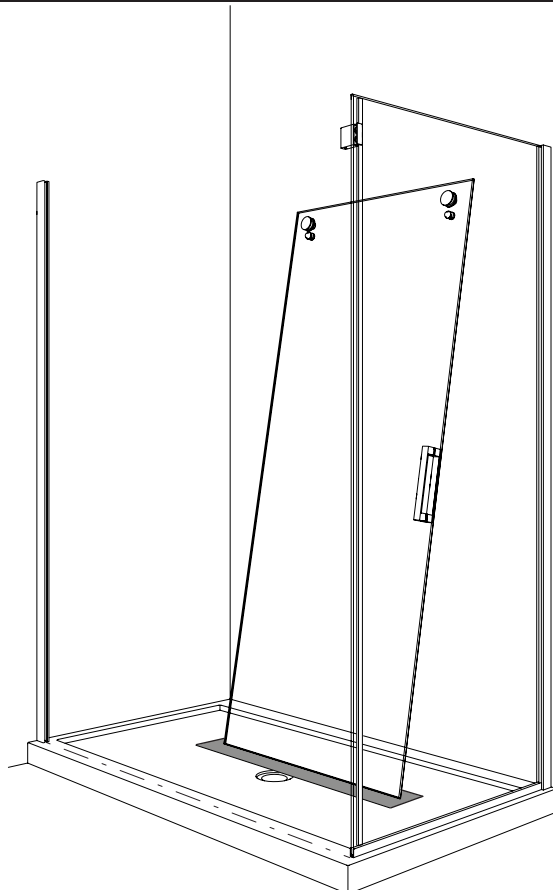

28

INSTALL THE U-CHANNEL FOR FIXED PANEL
INSTALLER LE PROFILÉ EN «U» POUR LE PANNEAU FIXE

A



Wipe the base with a clean cloth before installing the U-channel.

Essuyer la base avec un chiffon propre avant d'installer le profilé en «U».

B

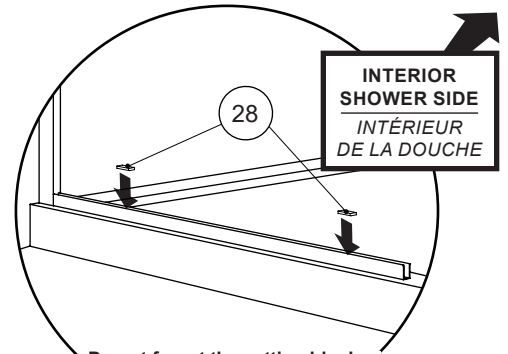
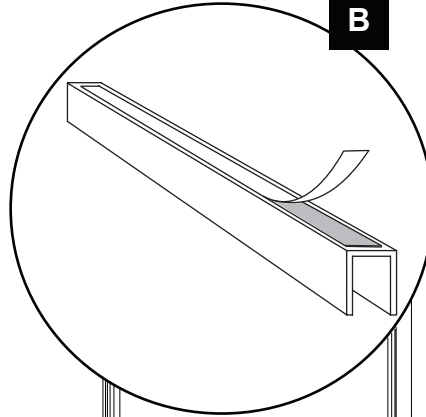

**INTERIOR
SHOWER SIDE
INTÉRIEUR
DE LA DOUCHE**

Do not forget the setting blocks.

Ne pas oublier les blocs de niveau transparents.

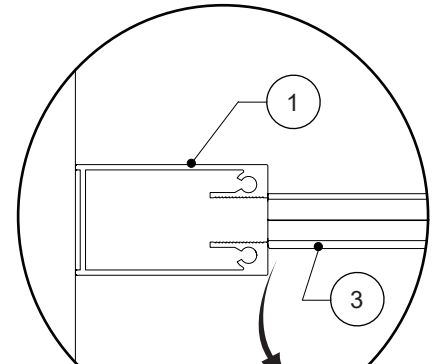

Make sure the U-channel is flush with exterior of walljamb

S'assurer que le profilé en «U» est aligné avec l'extérieur du jambage

29

INSTALL THE FIXED PANEL AND LEVEL / INSTALLER LE PANNEAU FIXE ET NIVELER

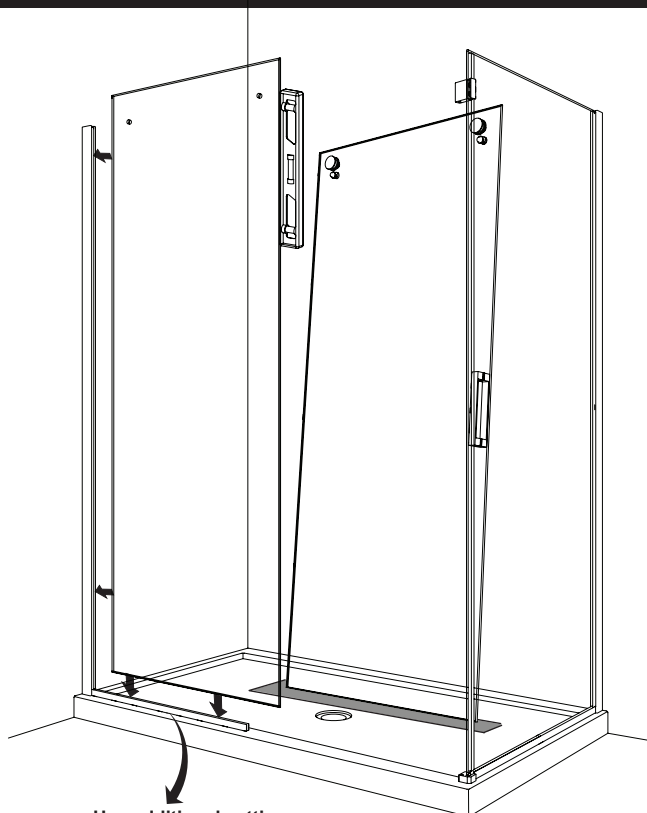

Use additional setting blocks to adjust if necessary.

Utiliser des blocs de niveau transparents supplémentaires pour ajuster si nécessaire.

30

PLACE AND MARK THE PLACEMENT OF THE U-CHANNEL AND BOTTOM GUIDE
PLACER ET MARQUER L'EMPLACEMENT DU PROFILÉ EN «U» ET DU GUIDE INFÉRIEUR

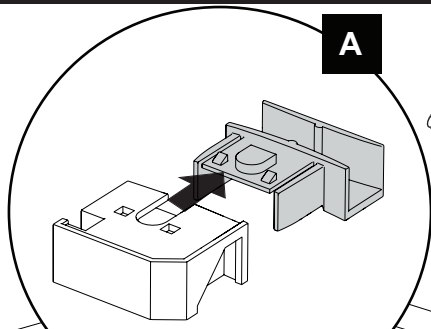

Remove the interior plastic part from bottom guide and mark the bottom guide hole .

Enlever la pièce intérieur en plastique du guide et marquer le trou du guide inférieur .

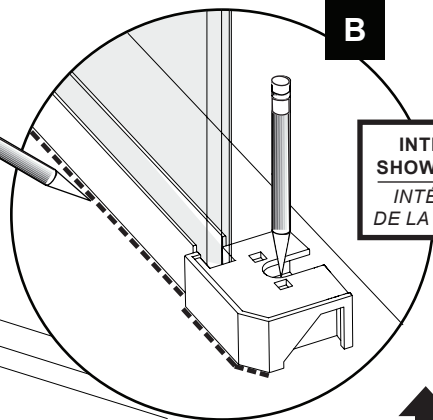

INTERIOR SHOWER SIDE
INTÉRIEUR DE LA DOUCHE

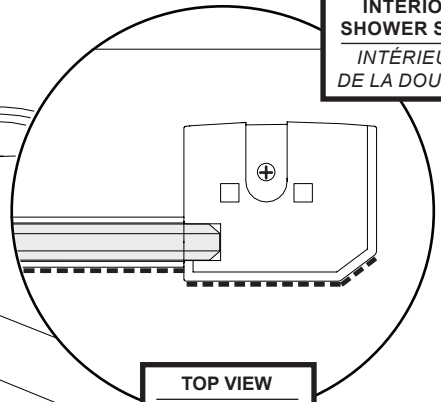

INTERIOR SHOWER SIDE
INTÉRIEUR DE LA DOUCHE

TOP VIEW
VUE DU HAUT

31

REMOVE THE FIXED PANEL / ENLEVER LE PANNEAU FIXE

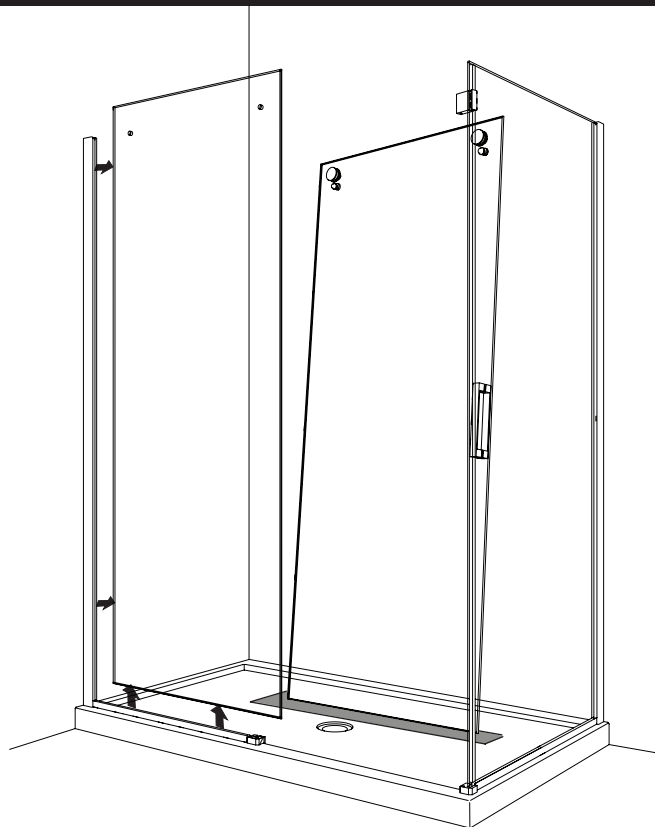

FORMULA FOR GASKET / FORMULE POUR LE JOINT



GASKET =FROM EXTERIOR OF BOTTOM GUIDE TO EDGE OF CORNER THRESHOLD

JOINT DU SEUIL= L'EXTÉRIEUR DU GUIDE INFÉRIEUR À L'INTÉRIEUR DE L'ANCRAGE DE SEUIL DE COIN

A



FORMULA FOR THRESHOLD / FORMULE POUR LE SEUIL



THRESHOLD =ADD 5/8" (16mm) FROM EXTERIOR OF BOTTOM GUIDE TO EDGE OF CORNER THRESHOLD

THRESHOLD = AJOUTER 5/8" (16mm) DE L'EXTÉRIEUR DU GUIDE INFÉRIEUR À L'INTÉRIEUR DE L'ANCRAGE DE SEUIL DE COIN

A + 5/8"

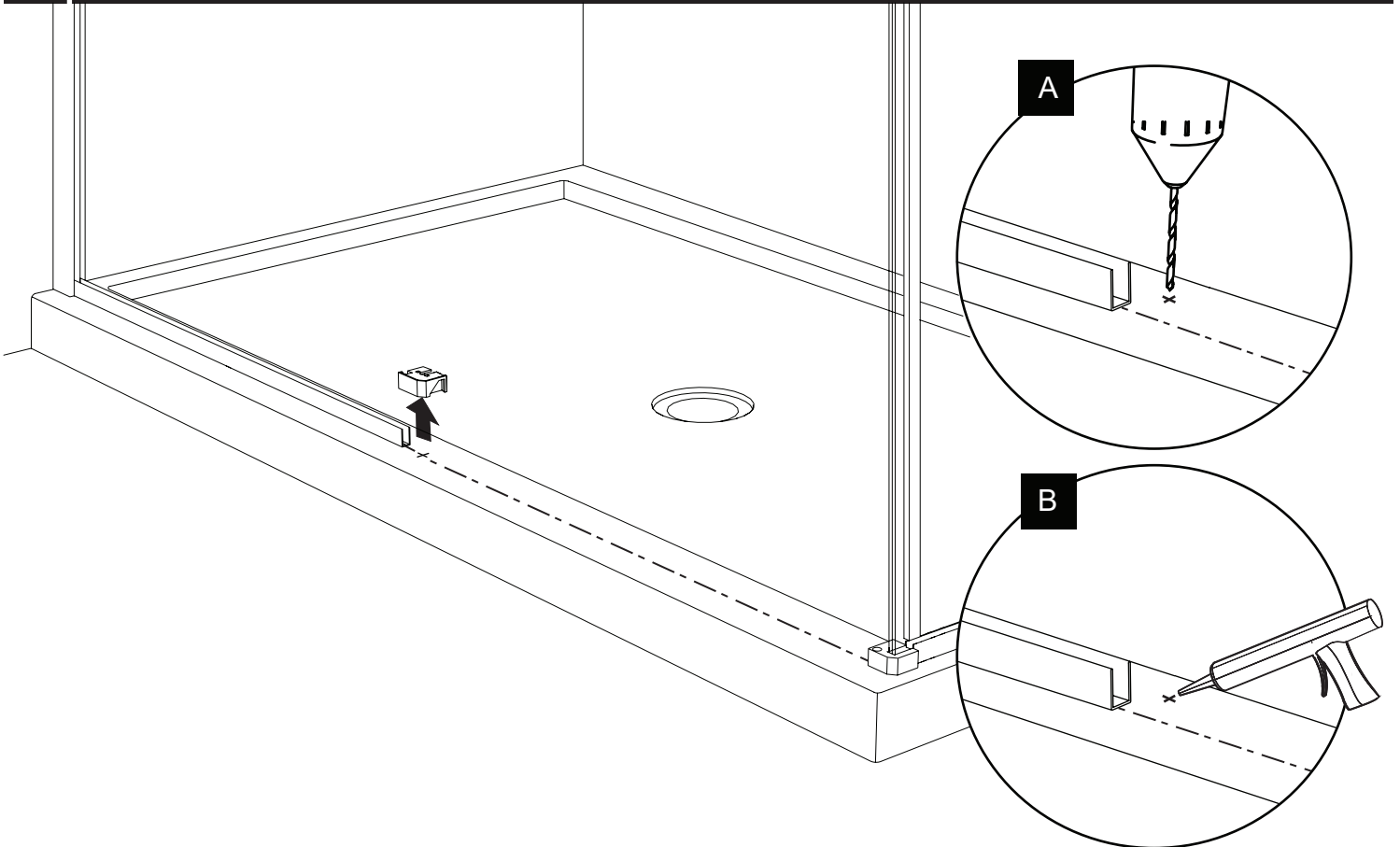
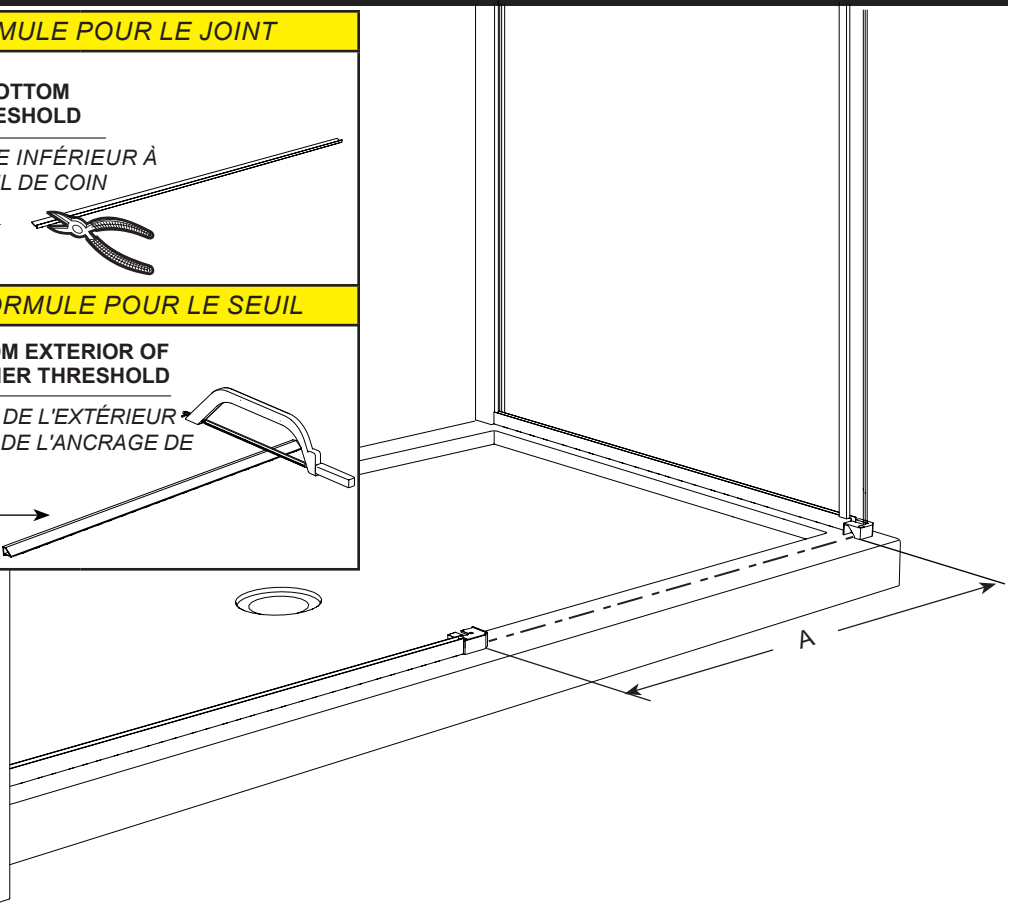
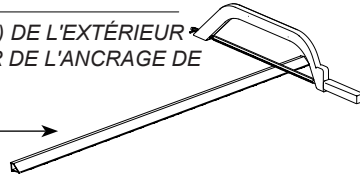

A

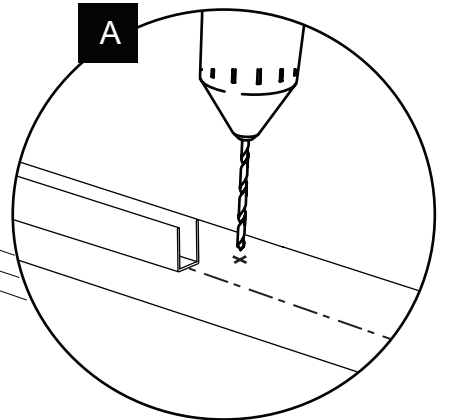

B

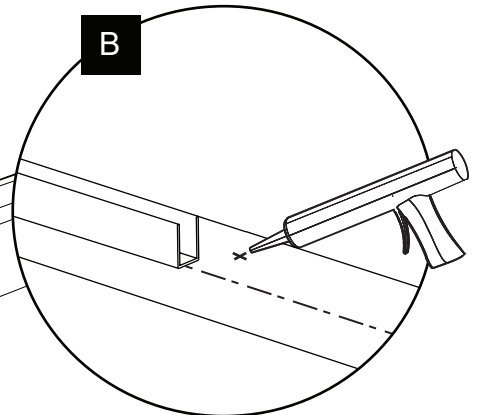

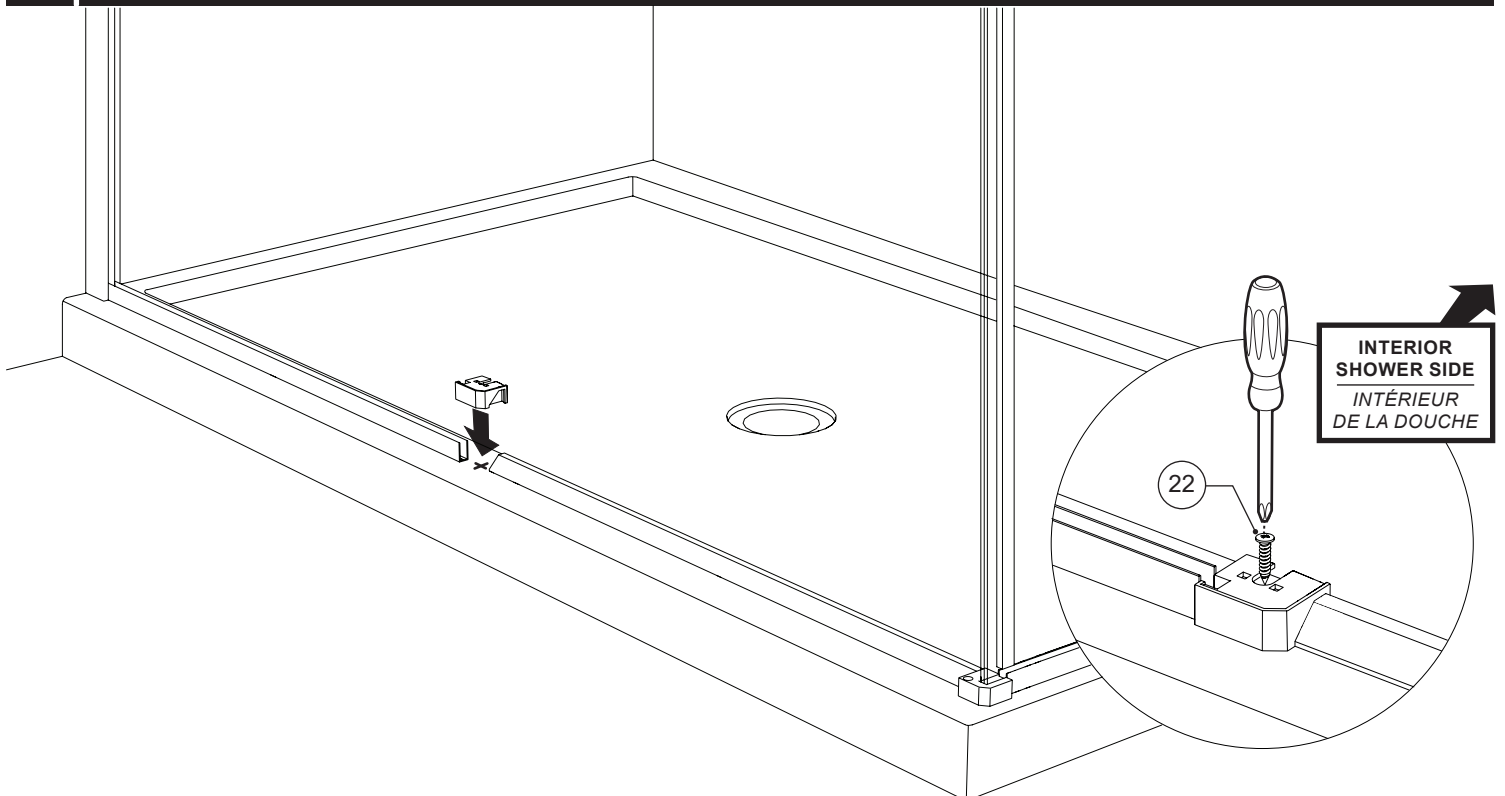
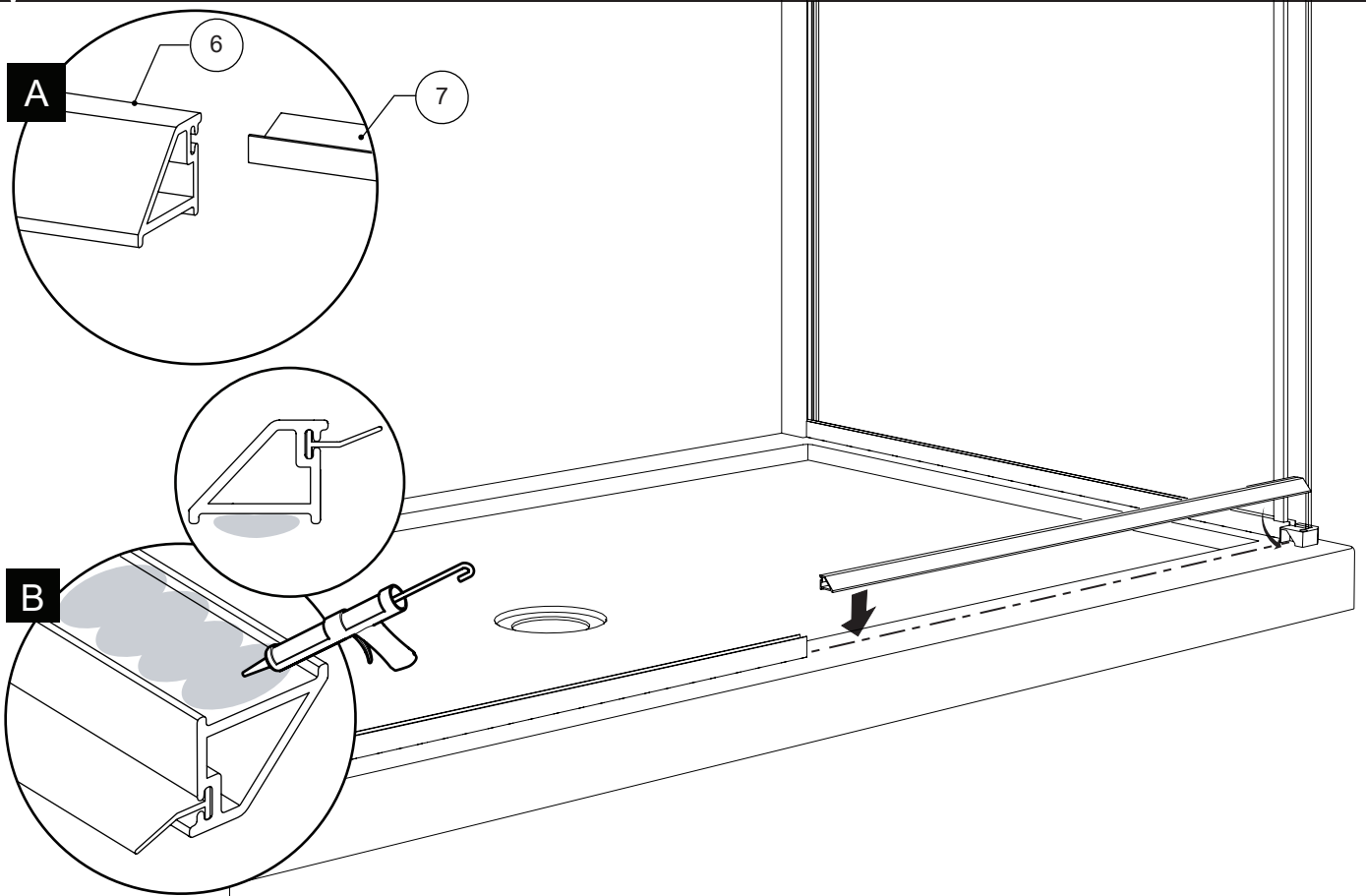



**Cut the running rail 3 1/4" (83mm) shorter than the opening.
Trim the running rail on the side with no holes**

Couper la barre de roulement 3 1/4" (83mm) plus court que l'ouverture. Couper la barre de roulement du côté sans trous

**Glass fastener holes
(fixed panel side).**

*Trous des fixations de verre
(côté du panneau fixe).*

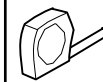
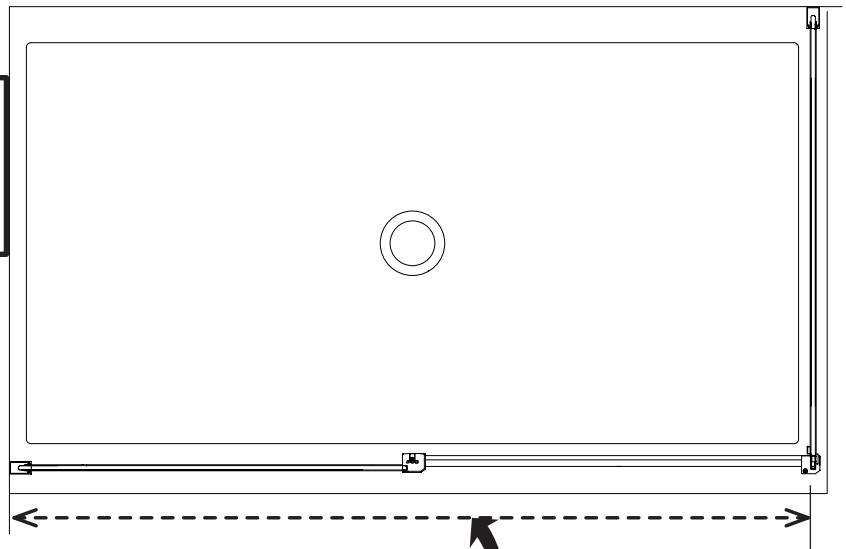
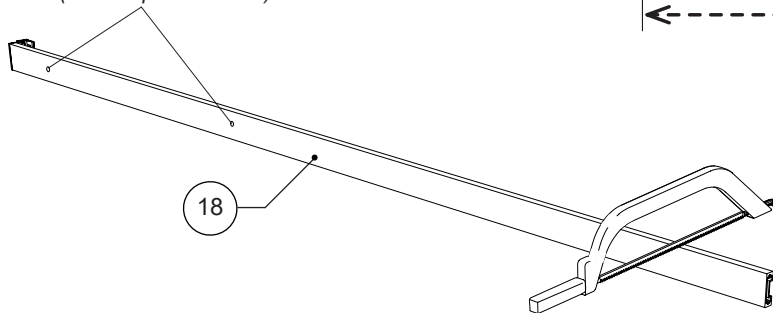

**Opening starts from fished wall
to inner face of return panel**

*L'ouverture est du mur fini au
centre du panneau de retour*

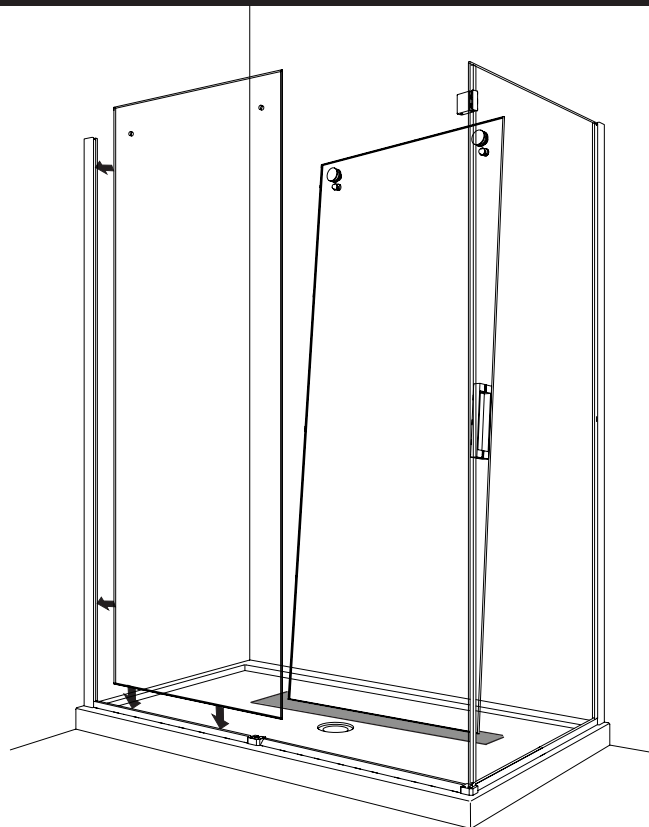

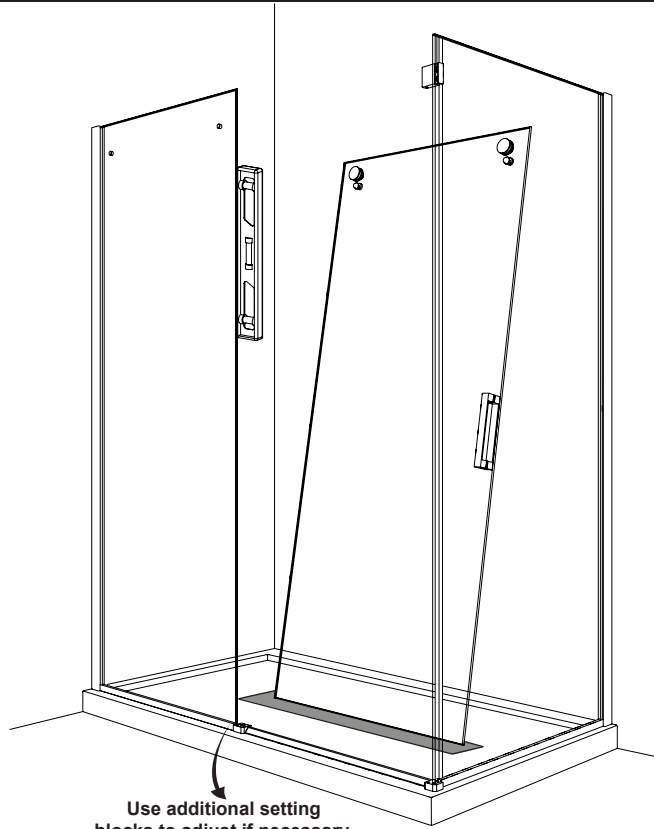

Use additional setting blocks to adjust if necessary.
 Utiliser des blocs de niveau transparents supplémentaires pour ajuster si nécessaire.

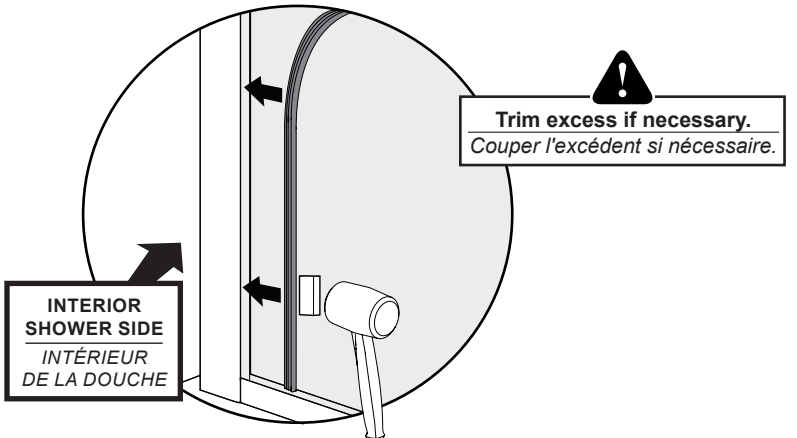
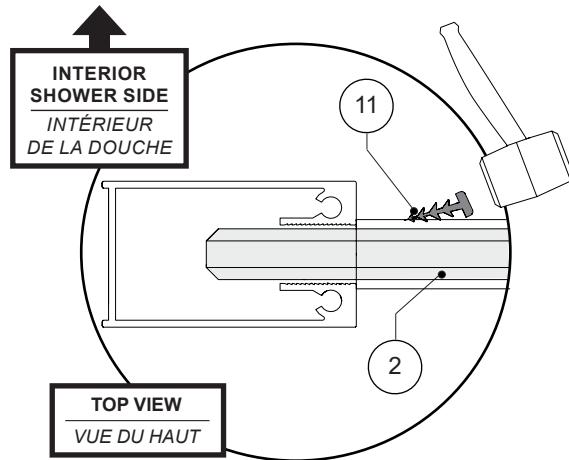
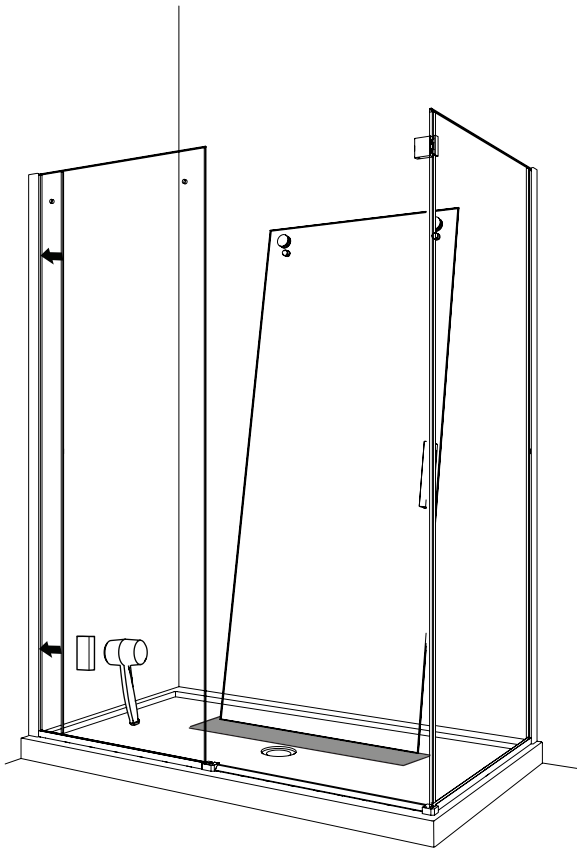

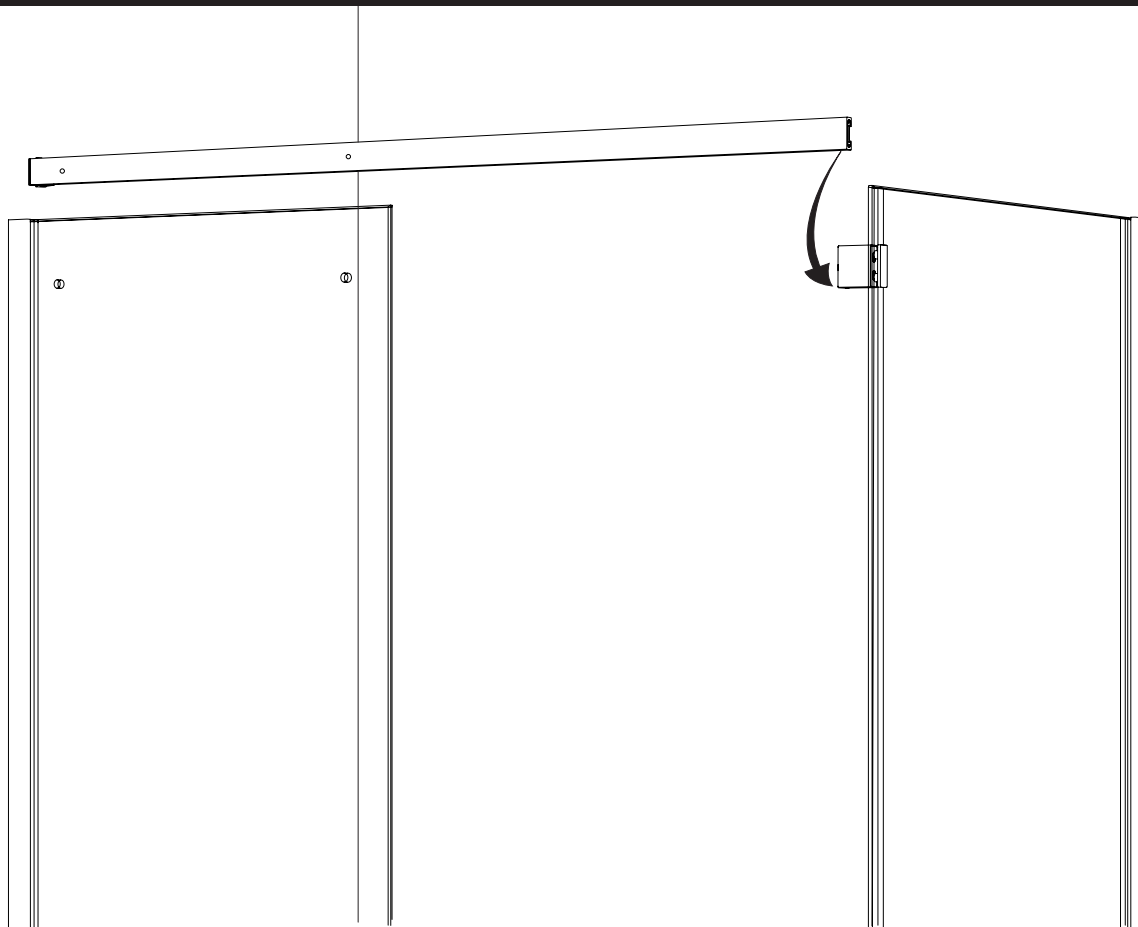

* **FOR SQUARE FASTENERS INSTALLATION ,REFER TO END OF THE MANUAL**
POUR INSTALLATION DES FIXATIONS CARRÉES ,RÉFÉRER À LA FIN DU MANUEL

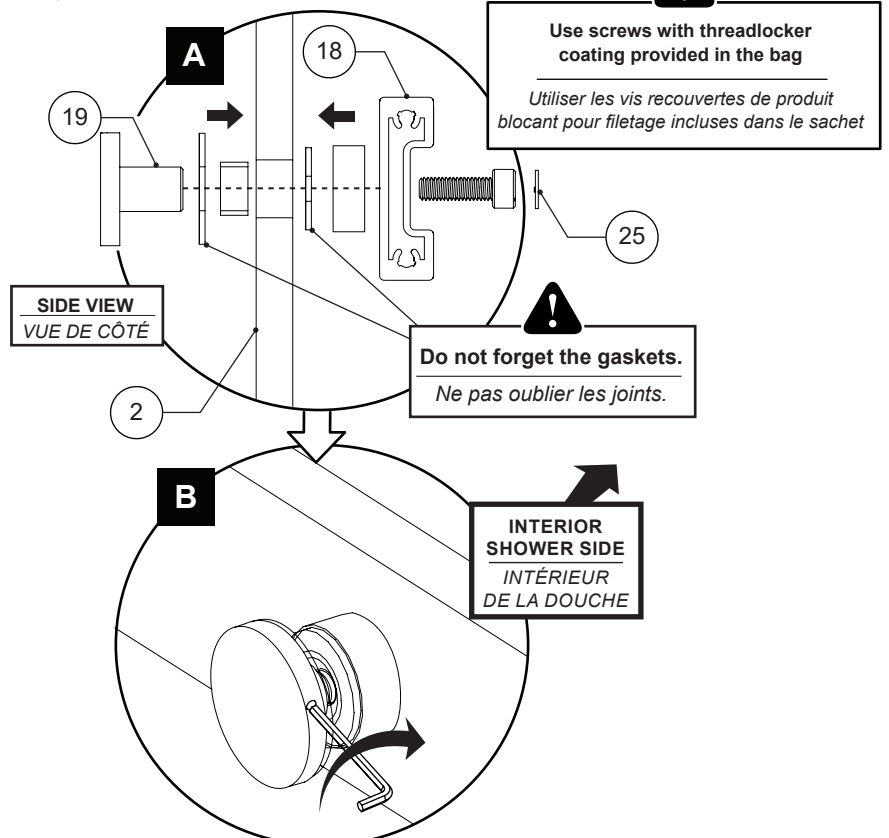
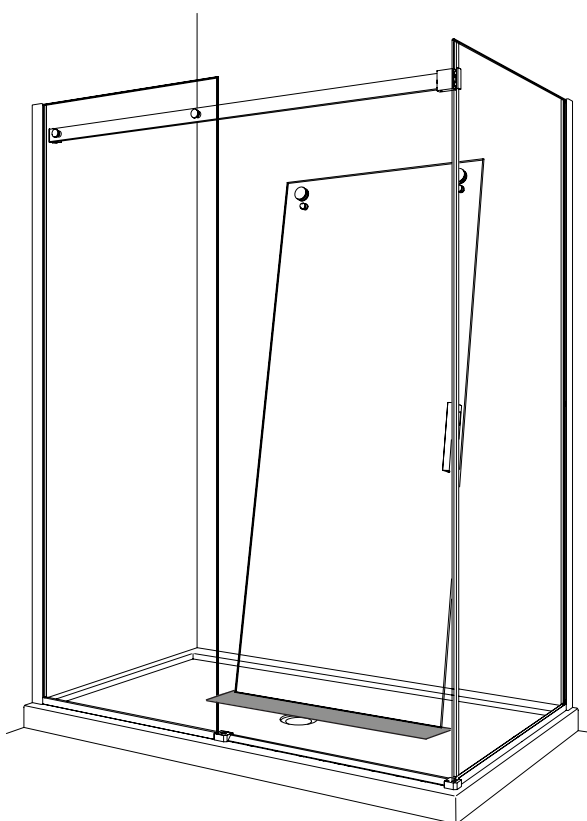

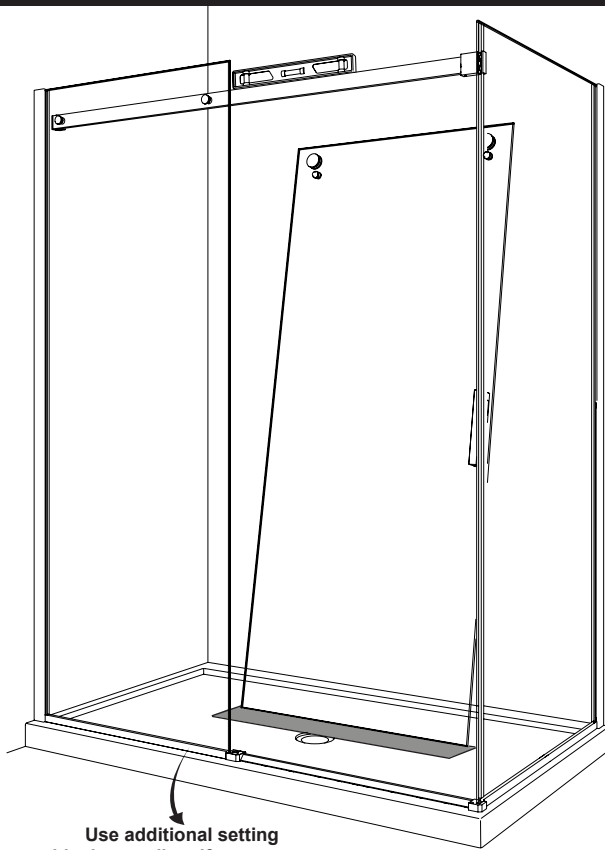

Use additional setting blocks to adjust if necessary.
 Utiliser des blocs de niveau transparents supplémentaires pour ajuster si nécessaire.

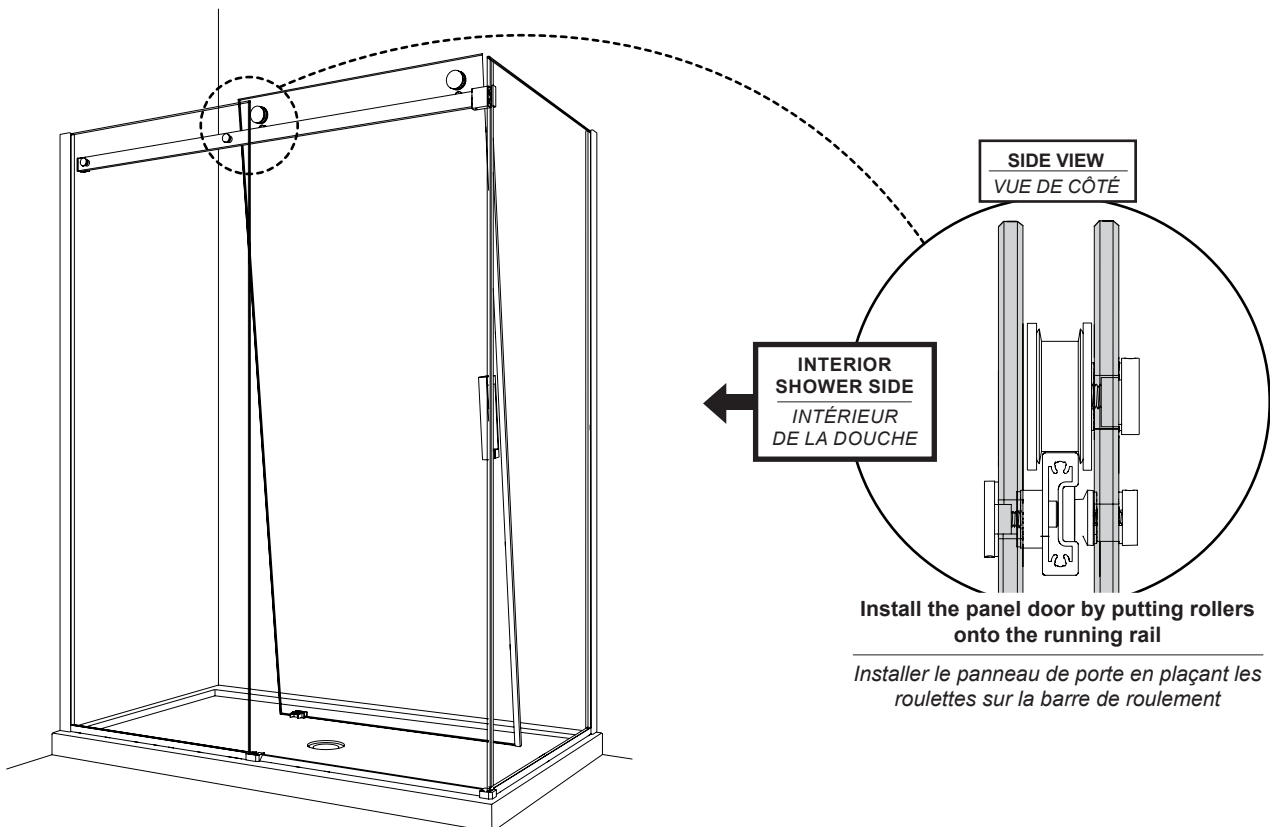

Install the panel door by putting rollers onto the running rail

Installer le panneau de porte en plaçant les roulettes sur la barre de roulement

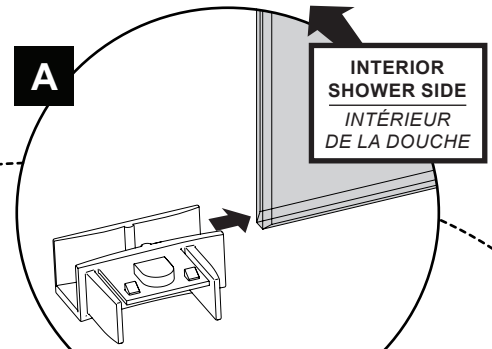
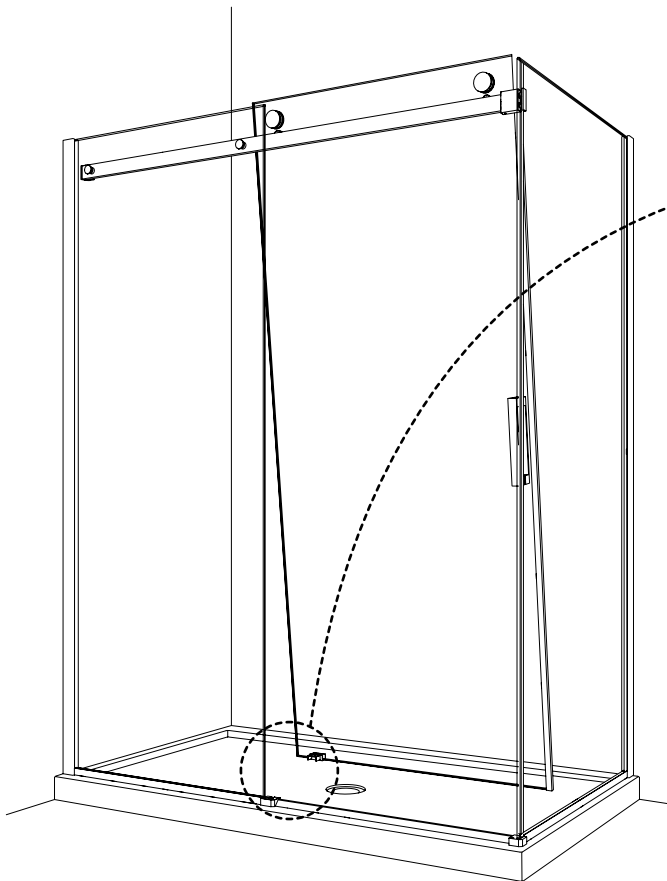

Insert the interior plastic part into the door panel

Insérer l'intérieur pièce en plastique sur la porte

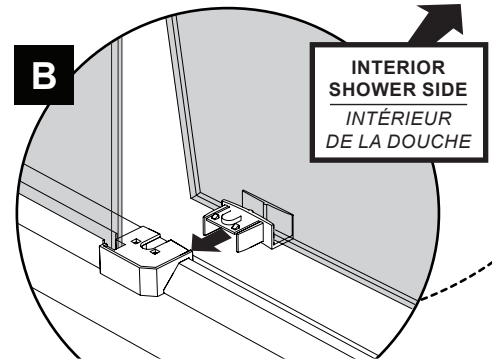

Insert the interior plastic part into the bottom guide

Insérer l'intérieur pièce en plastique dans le guide inférieur

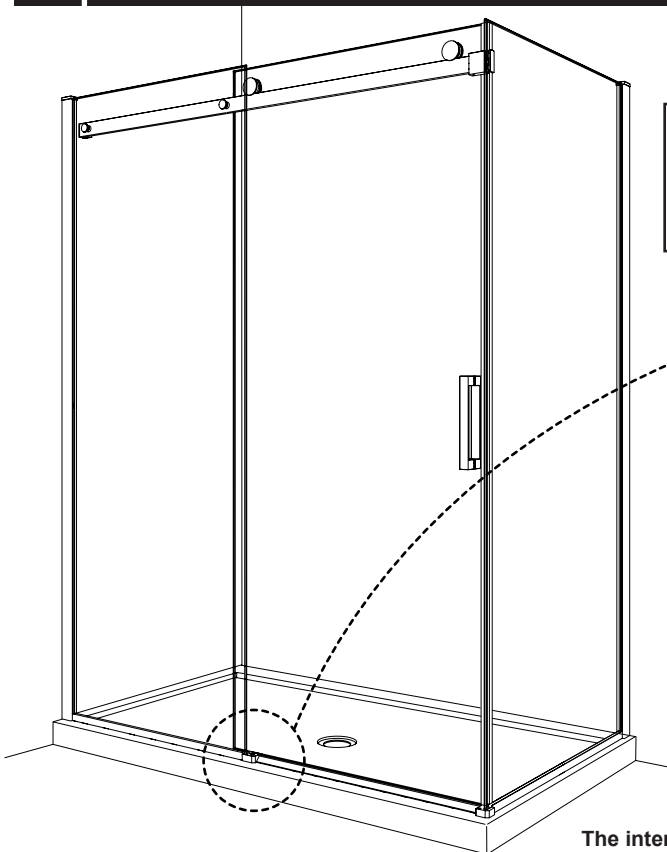

Push the panel door towards the interior to verify installation

Pousser le panneau de porte vers l'intérieur pour vérifier l'installation

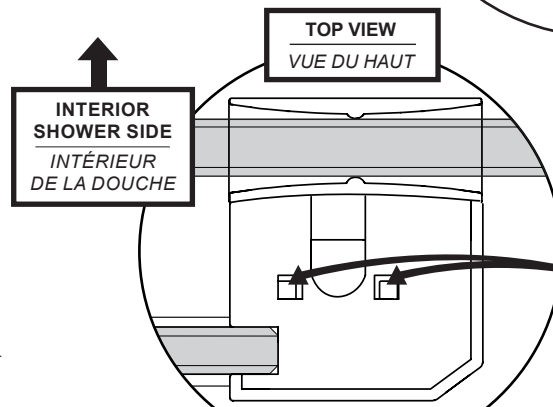
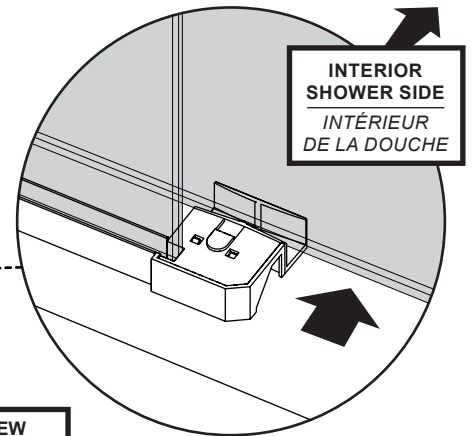

The interior plastic part must be inserted completely until the two square parts pop out

La pièce en plastique doit être insérée au maximum jusqu'à ce que les deux parties carrées ressortent

46 **INSTALL SIDE GASKET FOR THE DOOR PANEL AND FIXED PANEL**
INSTALLER LES JOINTS LATÉRAUX POUR LA PORTE ET LE PANNEAU FIXE

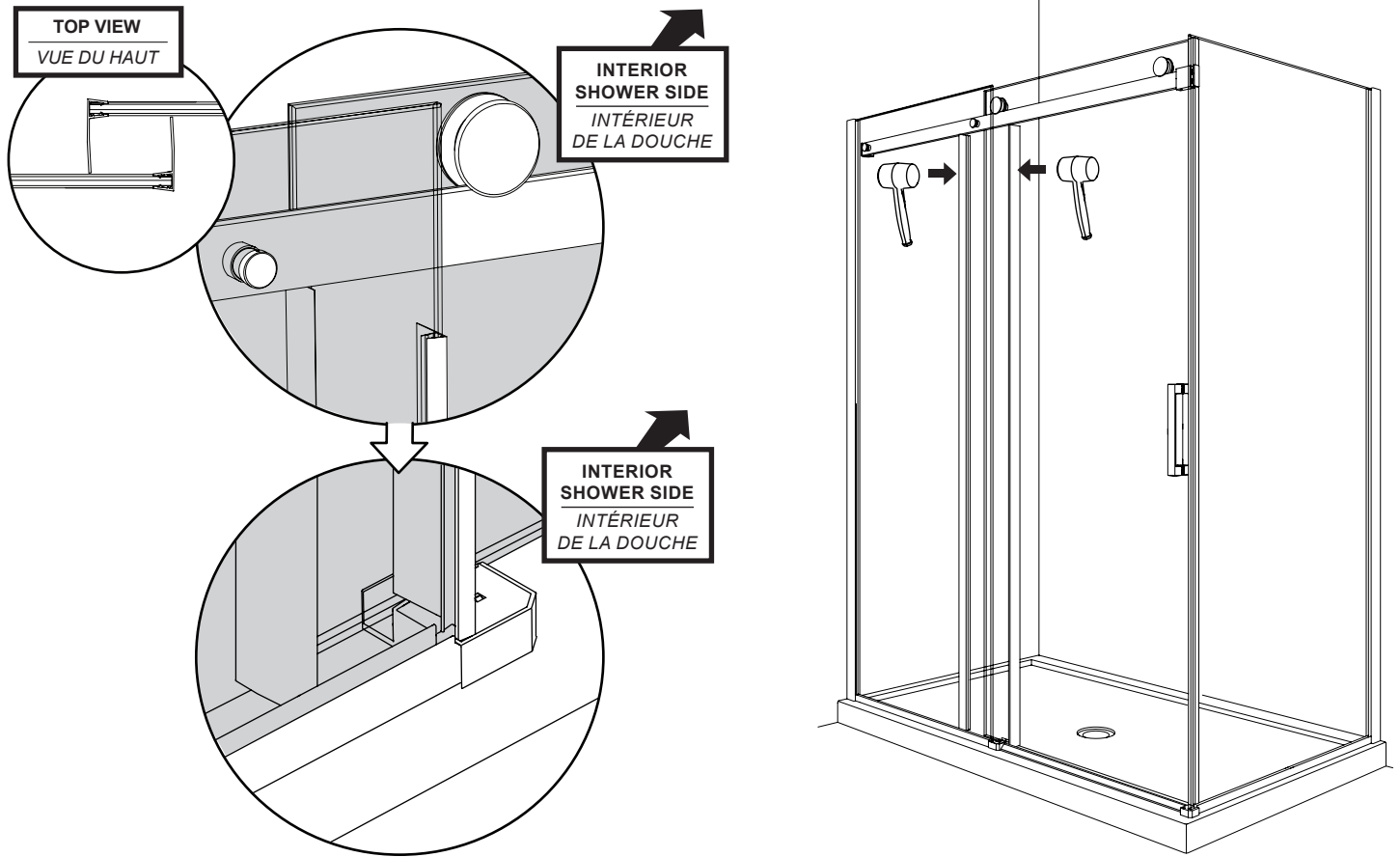

47 **ADJUST THE DOOR PANEL / AJUSTER LE PANNEAU DE PORTE**

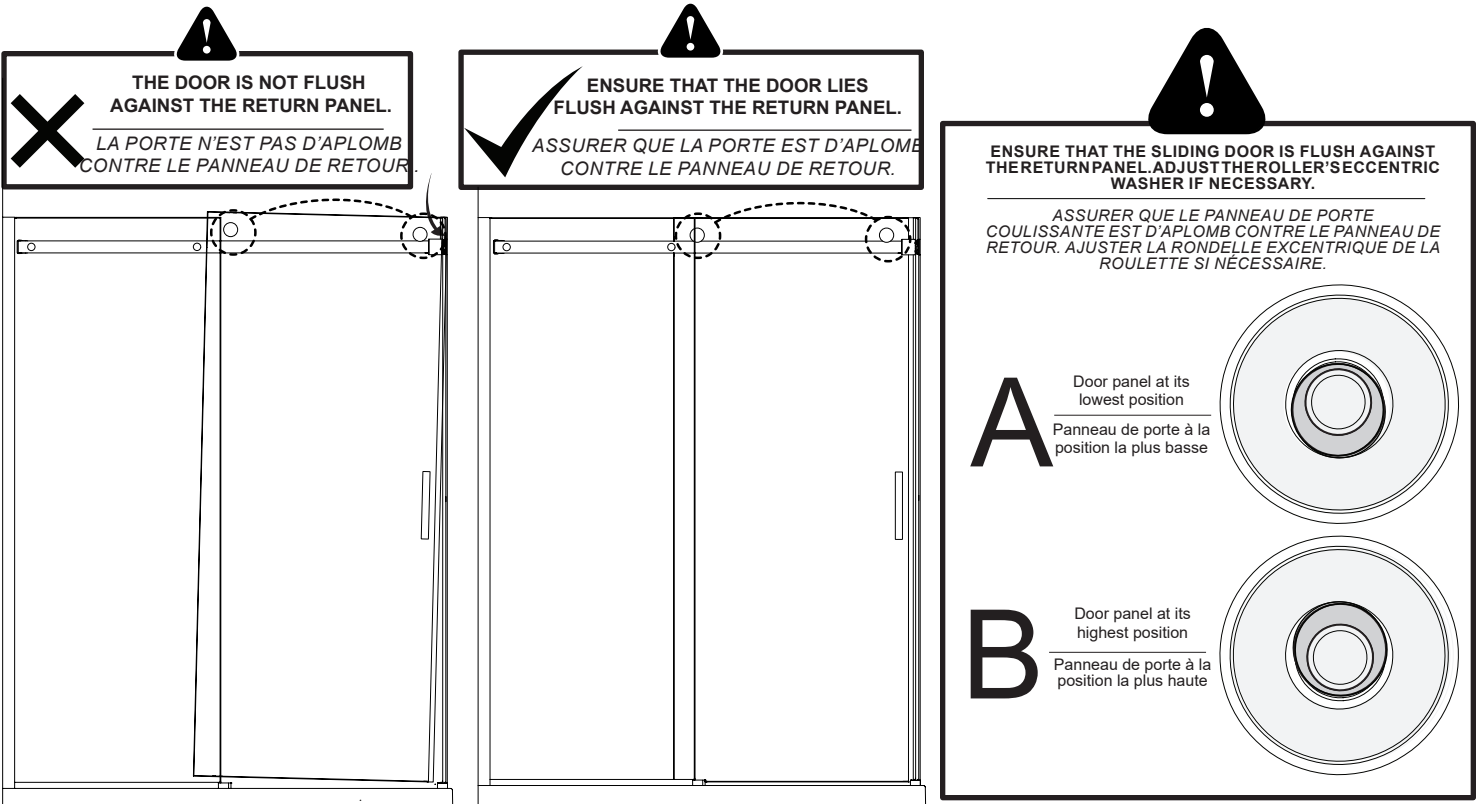

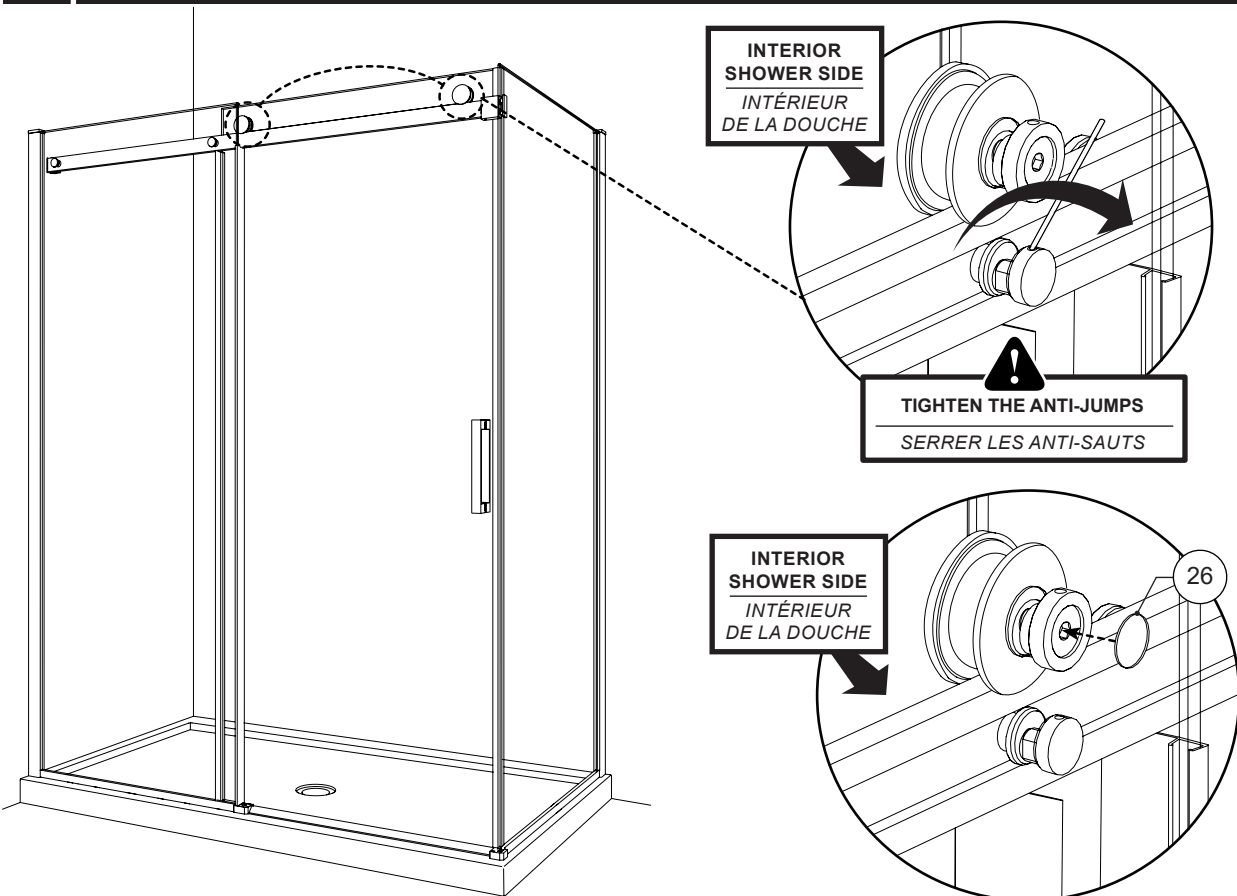
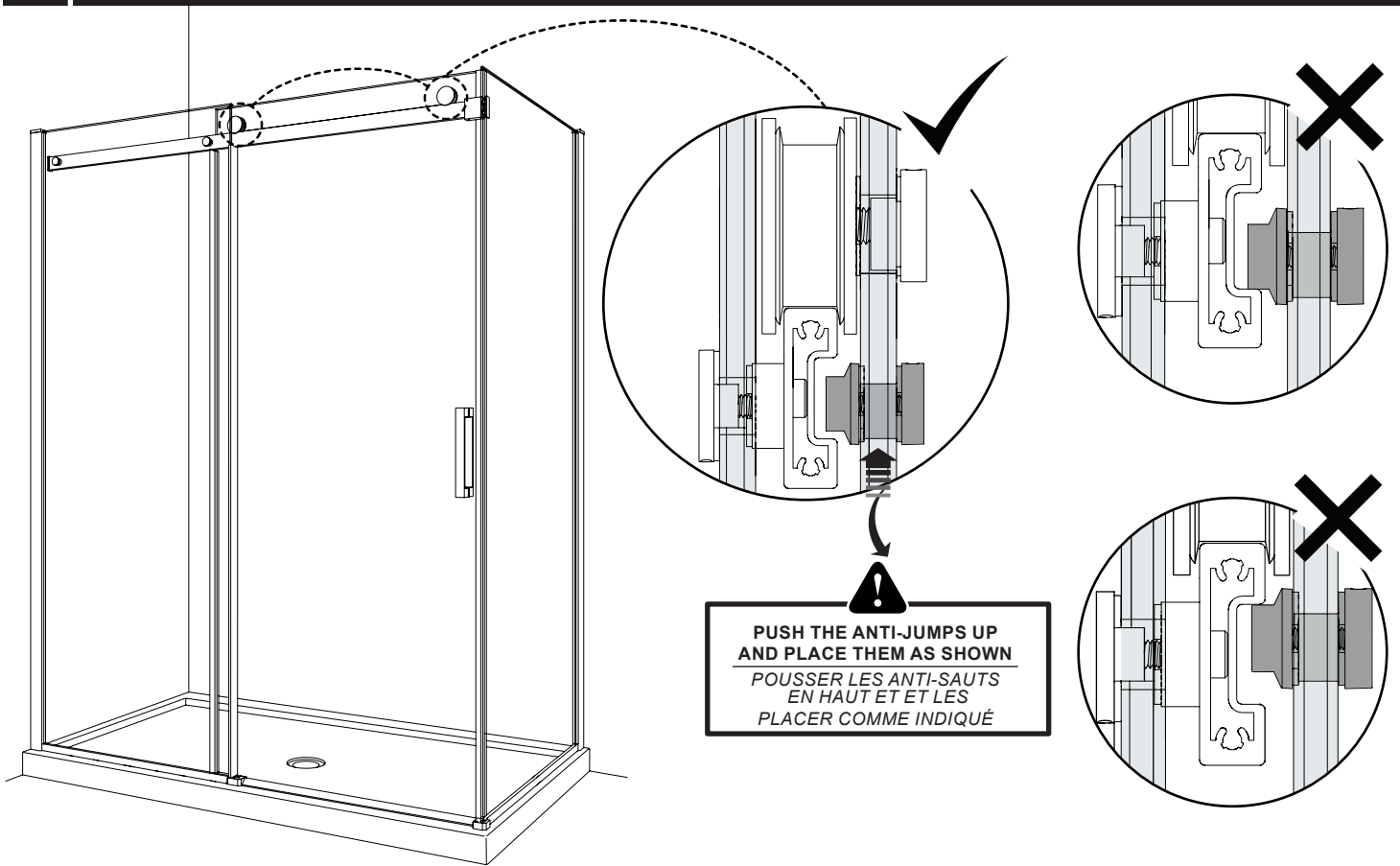

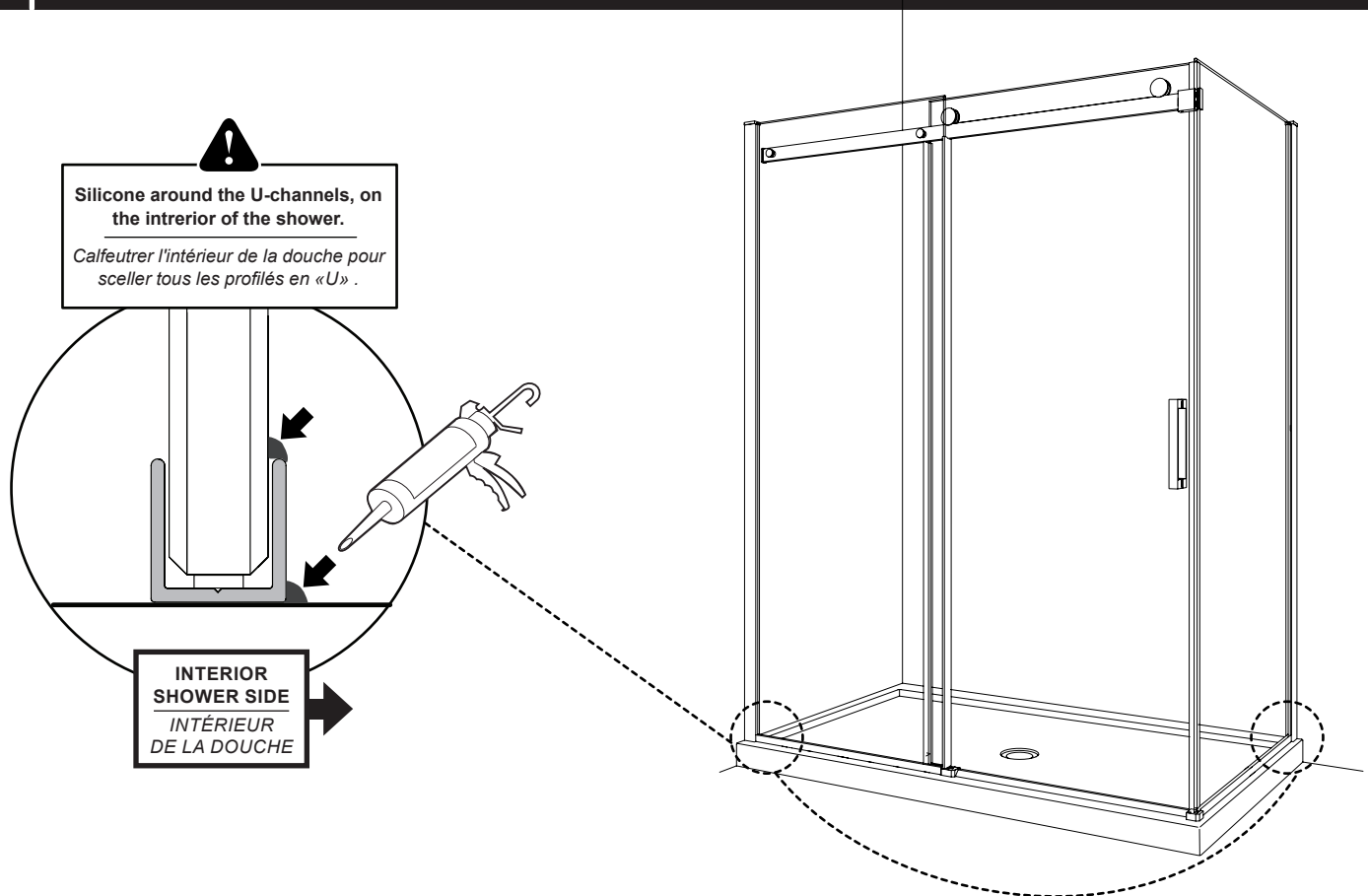
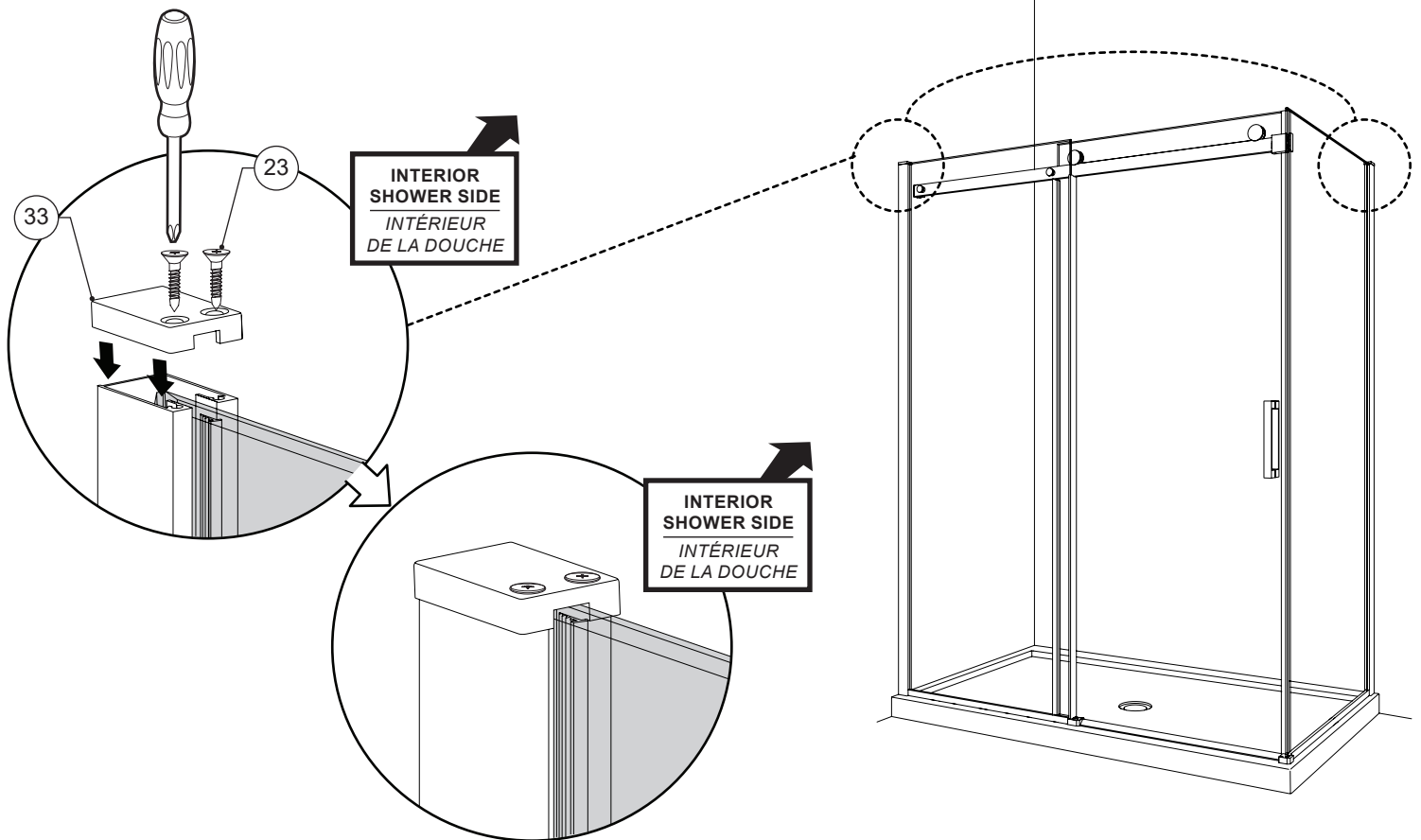

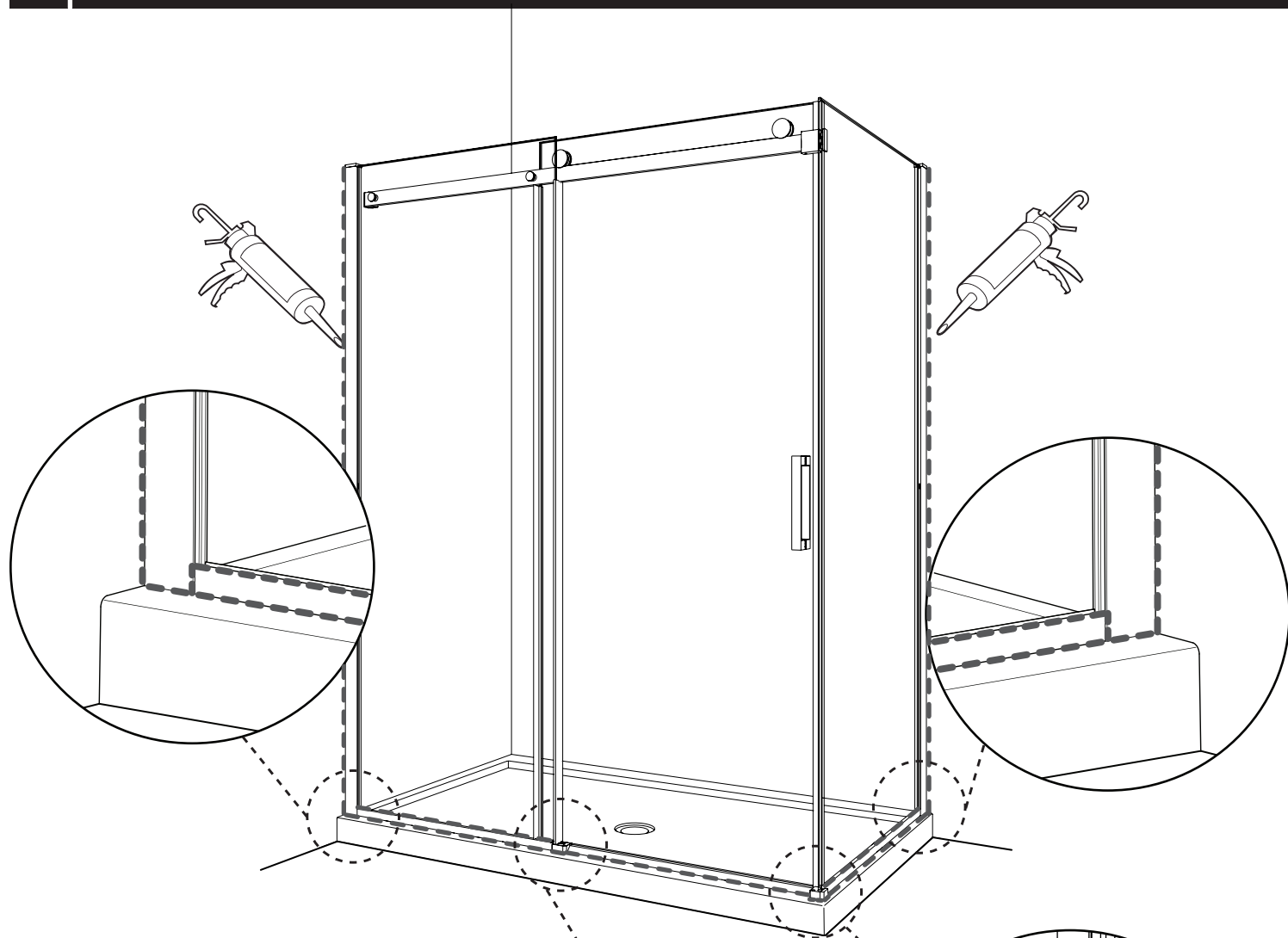

!
Silicone around the u-channels, exterior of the shower.
Calfeutrer l'extérieur de la douche pour sceller tout les profilés en «u» .

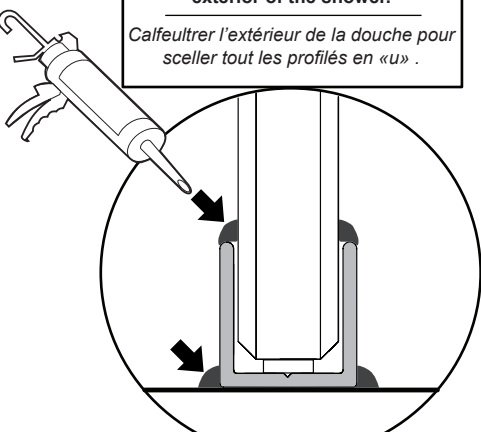

INTERIOR SHOWER SIDE
INTÉRIEUR DE LA DOUCHE →

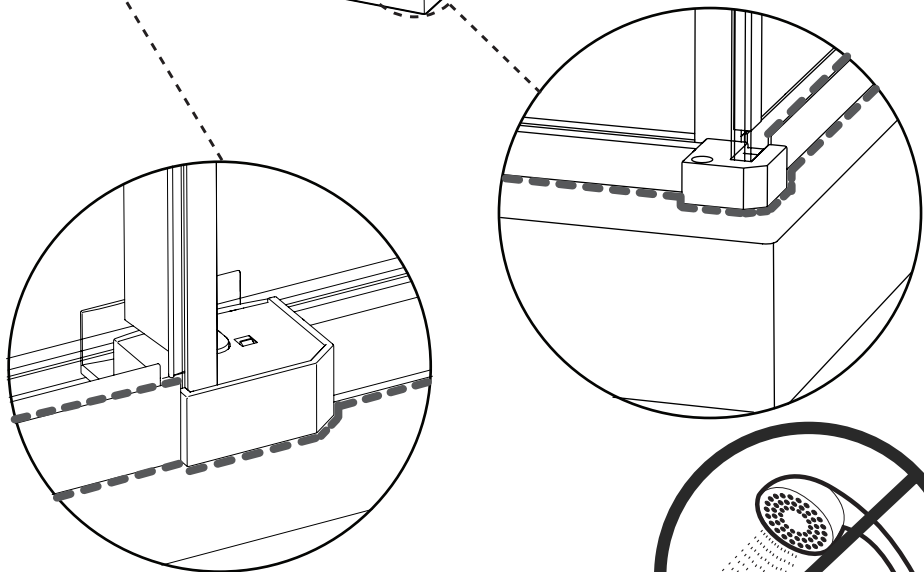

24 HOURS
 HEURES

15B INSTALL THE SQUARE ROLLERS / INSTALLER LES ROULETTES CARRÉES

* REFER TO STEP 23 / RÉFÉRER À L'ÉTAPE 23

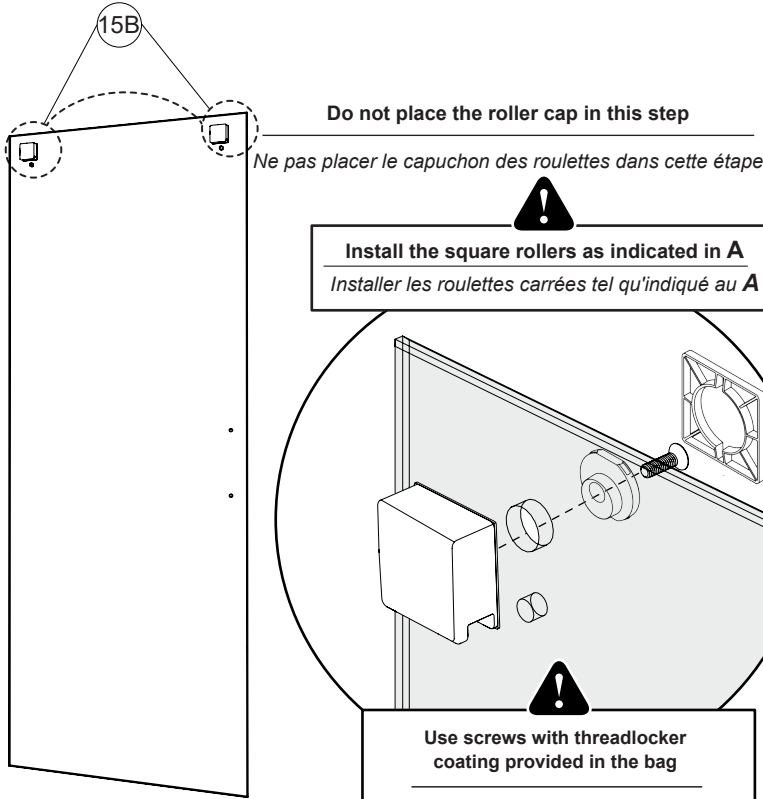

ATTENTION: To ease the installation on 15B, install the square rollers at the highest position as indicated image A
ATTENTION: Pour faciliter l'installation à l'étape 15B installer les roulettes carrées à la position la plus haute tel qu'indiqué au A

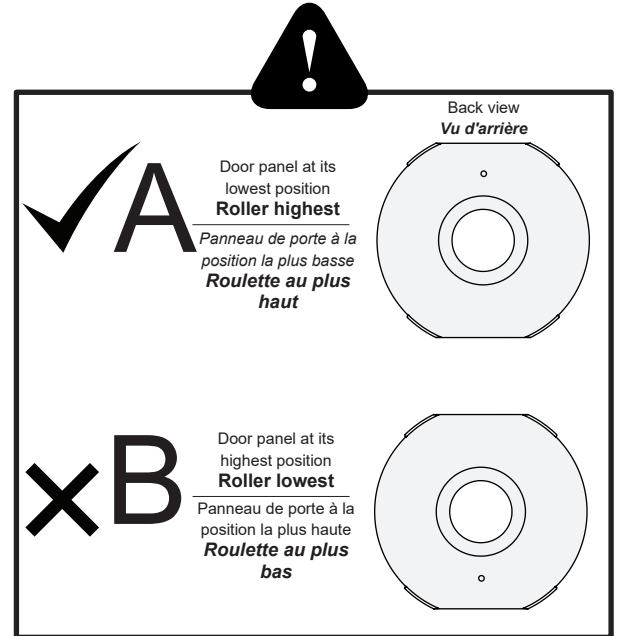

19D INSTALL THE SQUARE FASTENERS / INSTALLER LES FIXATION CARRÉES

* REFER TO STEP 41 / RÉFÉRER À L'ÉTAPE 41

