

JASON[®]

HYDROTHERAPY

8328 MacArthur Dr. • North Little Rock, AR 72118
 501.771.4477 • Fax: 501.771.2333
 Customer Service: 800.255.5766
 www.jasoninternational.com

Vivere[®] Collection Specifications

AO3252 SL/SR

MicroSilk[®] - Whirlpool

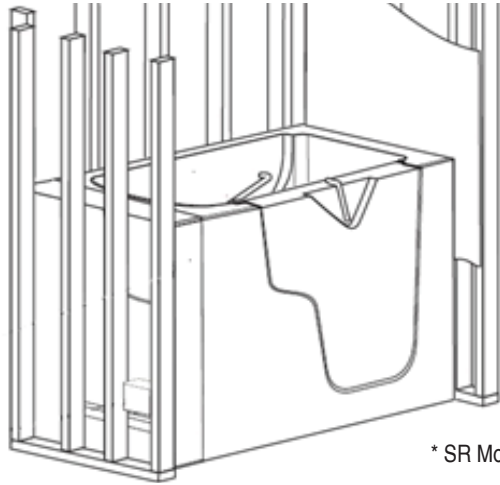

* SR Model shown

M MicroSilk[®] Unit Location

C Control Location

P Pump Location

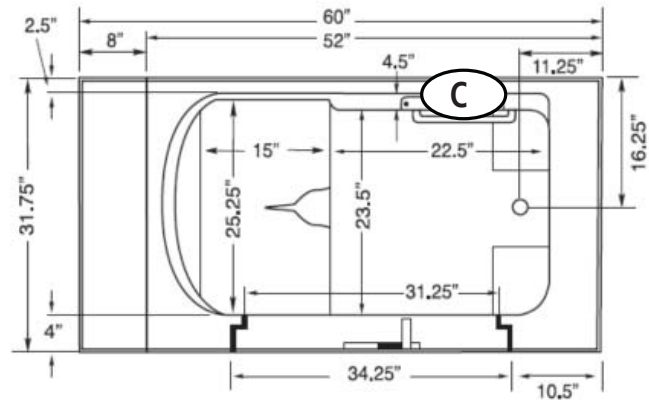
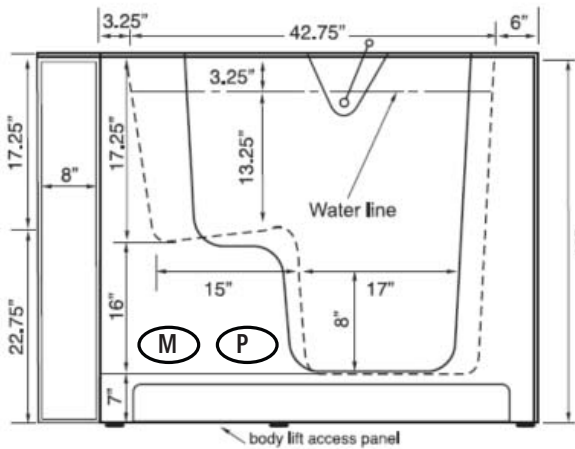

Patents received or pending.

Note: Dimensional Tolerances: $\pm 1/4$ "

Dimensions:	31.75" x 52" x 40"
Seat Height:	16"
Seat Dimensions:	15"L x 23.5"W x 17.25"H
Operating Capacity:	60 Gal.
Overflow Capacity:	65 Gal.
Floor Loading / sq.ft.:	103.3 lbs/sq.ft.
Carton Wt.:	305 lbs.
Cube:	47.7 ft. ³

Air Switch
Control

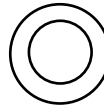

Includes a MicroSilk[®] unit, a whisper quiet 1-1/2 HP, 1 speed combination whirlpool pump/heater, (2) Chromatherapy Mood lights, Automatic Ozone System, an air switch On/Off Control and a 20-minute timer. Requires (1) 20A, 120V GFCI protected circuit.

Construction: Reinforced Dura Coat Shell mounted onto stainless steel frame.

We provide products listed with Intertek ETL SEMKO (Edison Testing Laboratories) U.S. and Canadian and with International Association of Plumbing and Mechanical Officials (IAPMO). Consult factory with your listing requirements.

- 8" Extension panel included to fit a 60" space
- Waste & Overflow drain kit included
- Left (SL) or Right (SR) door configurations available