

Kräus[®]

INSTALLATION MANUAL

Ceramic Bathroom Vessel Sinks

KCV-120 / KCV-121 / KCV-122 / KCV-125 /
KCV-126 / KCV-127 KCV-135 / KCV-140 /
KCV-141 / KCV-142 / KCV-150 / KCV-341

Congratulations on the purchase of your new Kraus plumbing fixture!

Please keep the box and packaging materials until your product is completely installed. If you have any questions, require technical assistance or have any problems with your product:

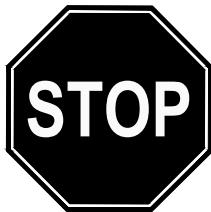

DO NOT RETURN TO STORE

**Please contact our Customer Service Team
1-800-775-0703 / customerservice@kraususa.com**

Have the model number available and retain a copy of your receipt with purchase date for reference.

If for any reason this product does not meet your expectations, please be sure to repack this product in the original box and packaging material to avoid damage during transit.

Prior to Installation:

- Make sure that you have all necessary parts by checking the parts list. If any part is missing or damaged, please contact Kraus Customer Service at 800-775-0703 for a replacement.
- Inspect the sink prior to installation to make sure that it has not been cracked or chipped during shipping.
- Observe all plumbing and building codes according to your state requirements
- Additional floor and wall preparation may be required to avoid damaging the sink

WARNING: This product is fragile and can break, chip or cause injury if handled recklessly. Please consult with a professional when installing.

For technical assistance or replacement parts, please contact Kraus Customer Service and one of our representatives will be happy to help:

Toll-Free: 800-775-0703 or customerservice@kraususa.com

The step-by-step guidelines in the installation instructions are a general reference for installing a Kraus Sink. Should there be any discrepancies, Kraus cannot be held liable. It is recommended to install all Kraus products by hiring a licensed professional.

Tools you will need

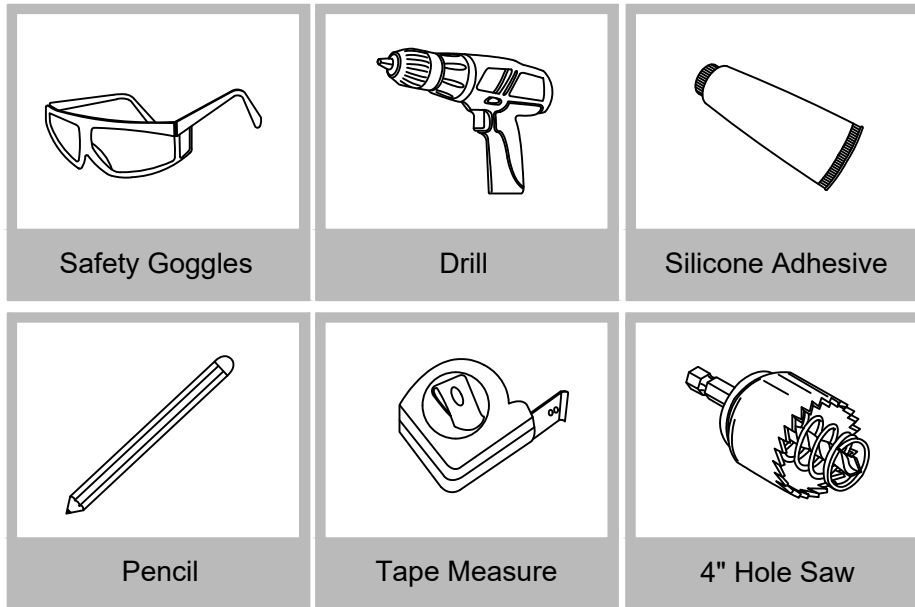

Dimensions

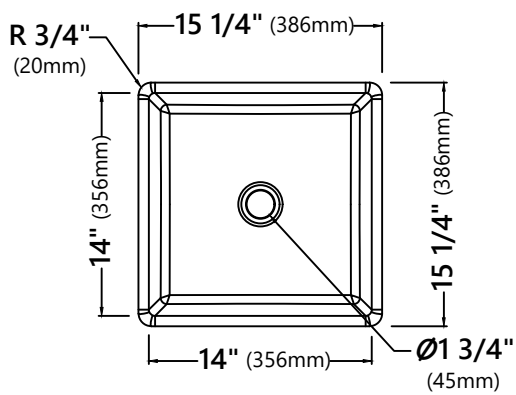

KCV-120
15 1/4 " x 15 1/4 " x 5 1/2"

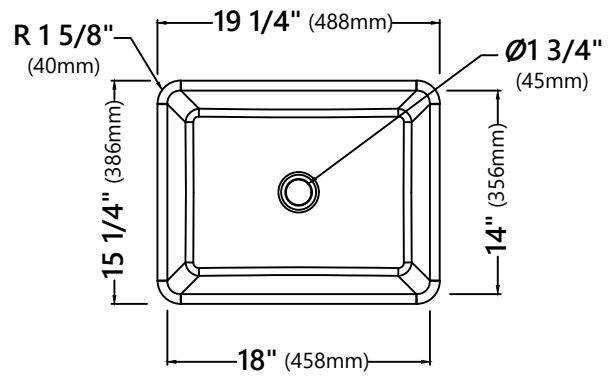

KCV-121
19 1/4 " x 15 1/4 " x 5 3/8"

Dimensions

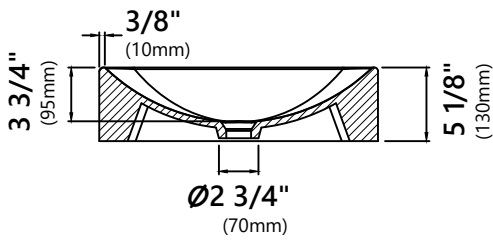
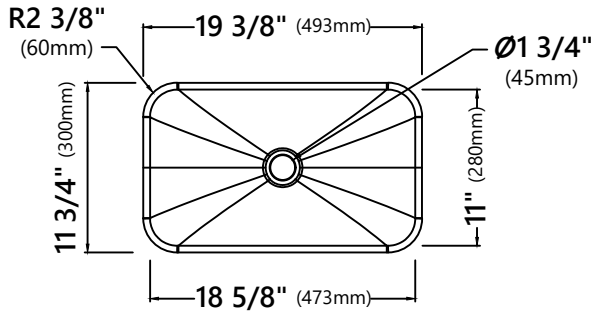

KCV-122
19 3/8" x 11 3/4" x 5 1/8"

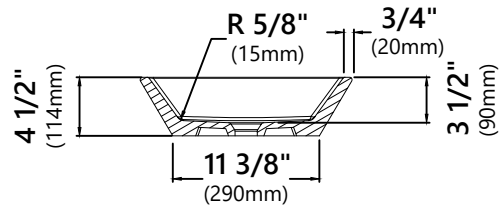
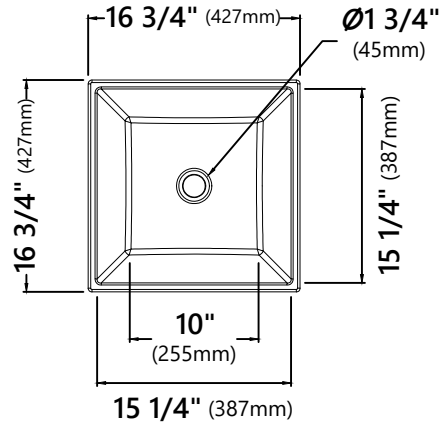

KCV-125
16 3/4" x 16 3/4" x 4 1/2"

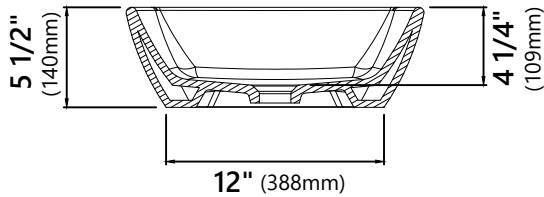
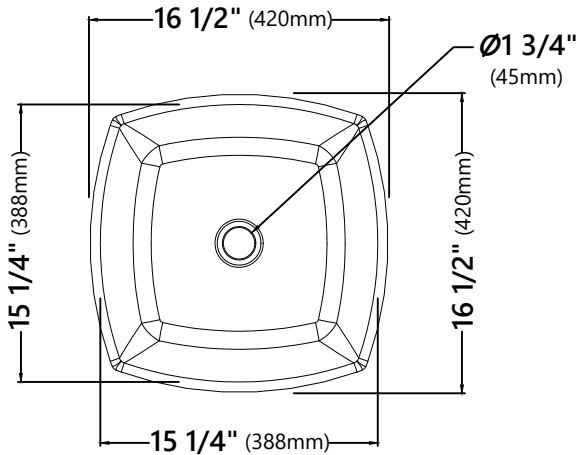

KCV-126
16 1/2" x 16 1/2" x 5 1/2"

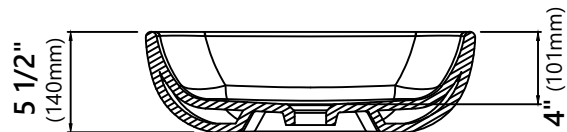
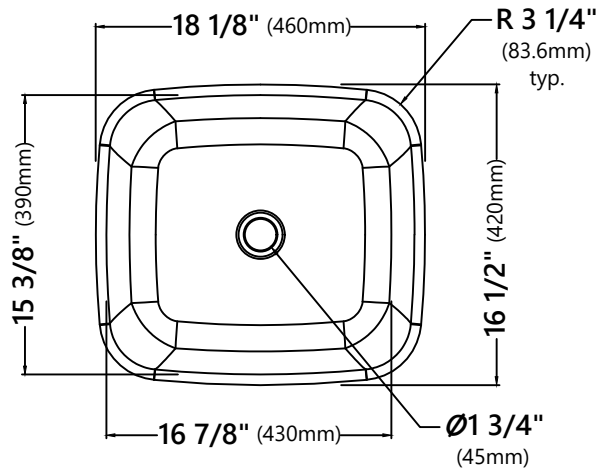

KCV-127
18 1/8" x 16 1/2" x 5 1/2"

Dimensions

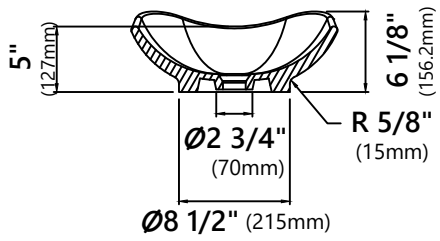
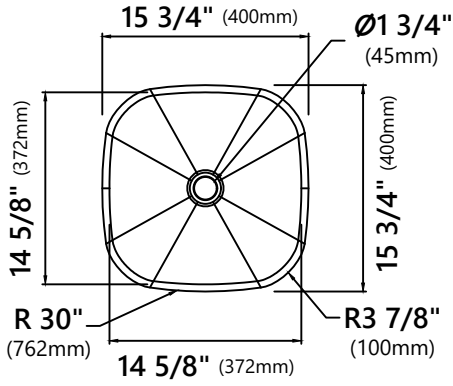

KCV-135
15 3/4 " x 15 3/4 " x 6 1/8"

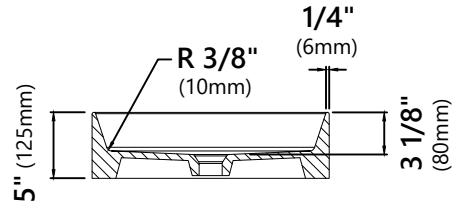
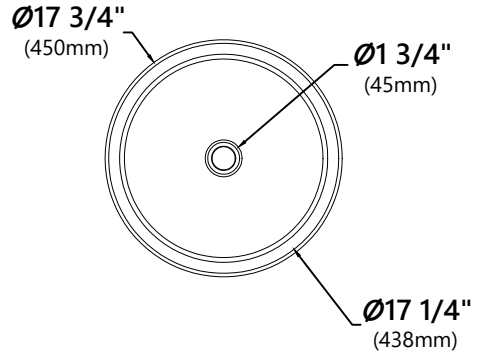

KCV-140
Ø17 3/4 " x 5"

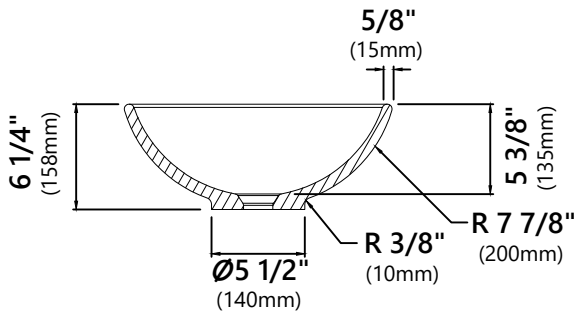
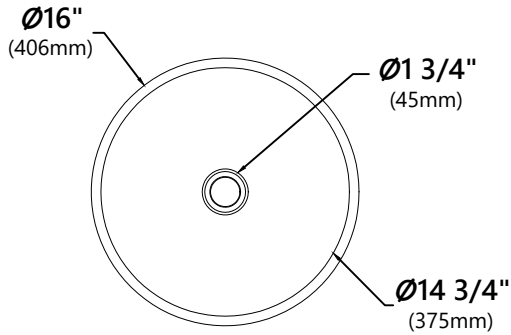

KCV-141
Ø16" x 6 1/4"

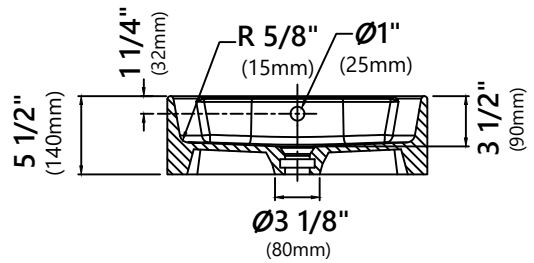
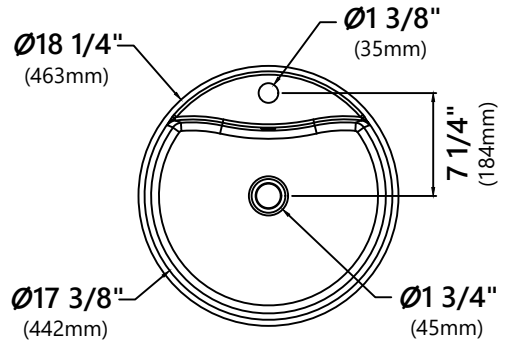

KCV-142
Ø18 1/4 " x 5 1/2"

Dimensions

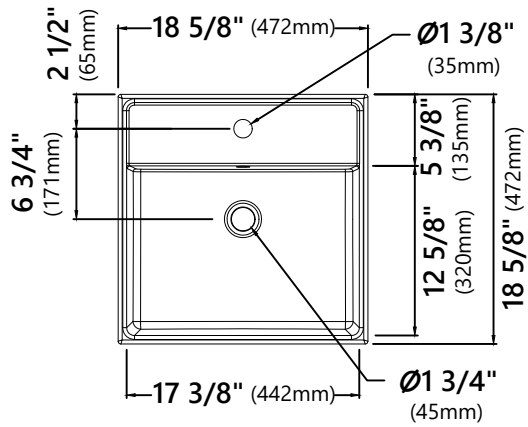

KCV-150
18 5/8" x 18 5/8" x 5 3/4"

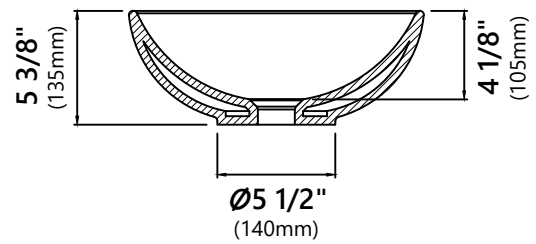
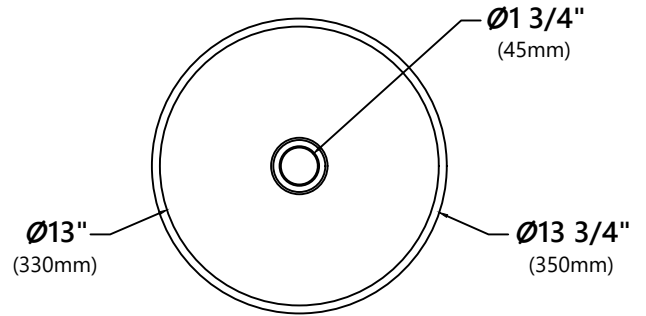

KCV-341
 $\varnothing 13\ 3/4"$ x 5 3/8"

1. Mark Faucet and Drain Hole Location

- Place sink in desired location on countertop and mark drain hole and faucet hole centerline with a pencil.

NOTE: Make sure clearance is suitable for backsplash, faucet, and sink plumbing.

NOTE: Please allow a minimum of 4.5" from wall to edge of sink for faucet placement clearance.

NOTE: For model numbers **KCV-142** and **KCV-150**, faucet hole location should be measured from center of drain hole to center of faucet hole on sink.

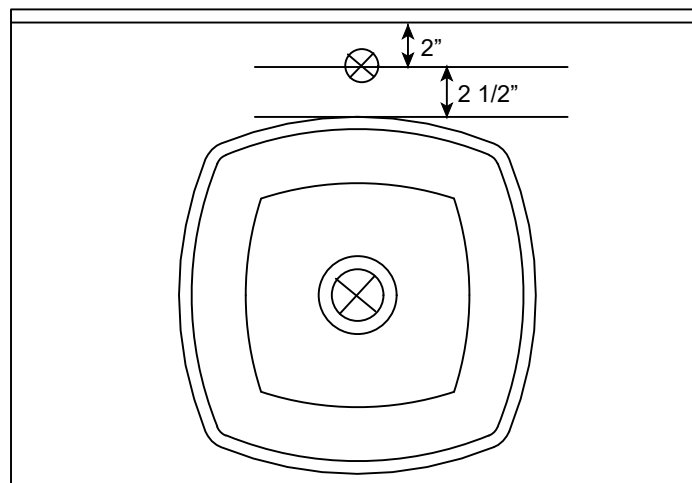

2. Drill Countertop

- Cut the drain opening in the countertop by carefully placing the 4" hole saw on the area marked by pencil.

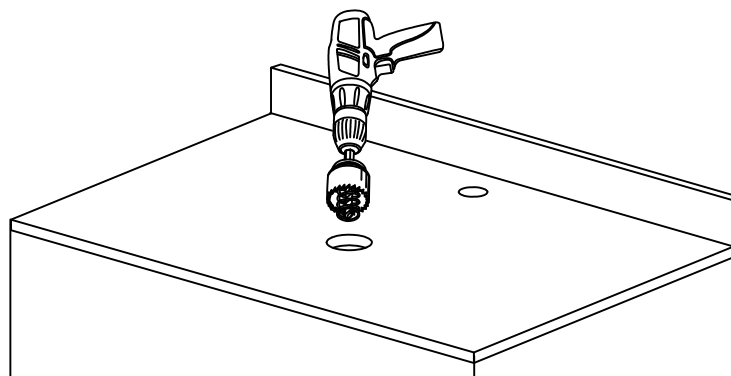

3. Install Sink

- Check the alignment of the sink to the opening in the countertop. Use a bead of clear silicone (or preferred adhesive) around the underside of the sink.
- Carefully place the sink on the countertop, align, and press firmly
- Allow sealant to set for 30 – 60 minutes

NOTE: Please make sure Kraus logo is facing you when mounting sink

NOTE: Use acetone or rubbing alcohol to remove any excess sealant immediately after application

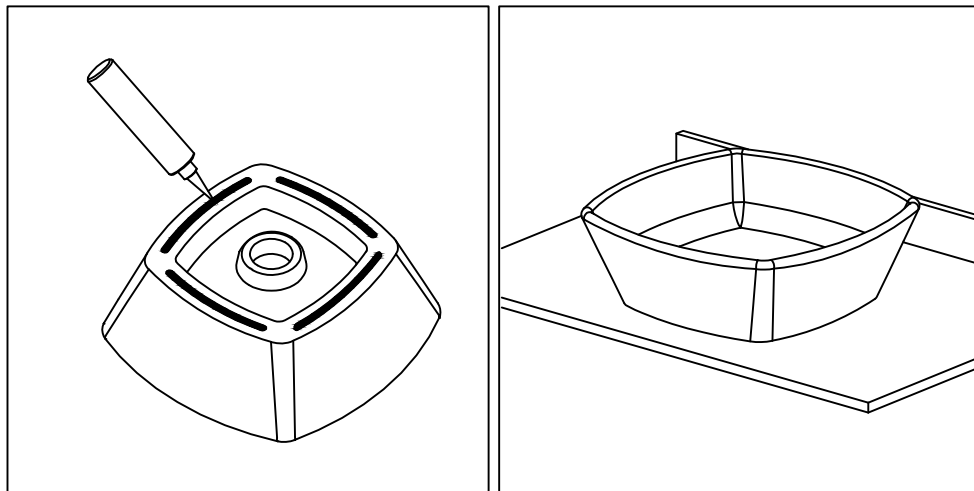

4. Install Plumbing Fixtures

- Connect drain to sink. Connect trap to drain. Connect water supply connections to faucet according to manufacturer's instructions.
- Run water into sink and check for leaks.

Codes/Standards Applicable:



Ceramic Bathroom Sink Warranty

Kraus products are manufactured and tested to the highest quality standards by Kraus USA Inc. ("Kraus").

Kraus extends this warranty to the original purchaser for personal household use of the "**Ceramic Sink**" in its original location. The warranty is non-transferable.

Kraus warrants the structure and finish of the product (**Ceramic Sink**) to be free from defects in material and workmanship under normal usage for the lifetime of the product. The warranty commences from the initial date of purchase by the owner or trade professional, from an authorized Kraus dealer, through the lifetime of the original owner or end-user.

Any product reported to the authorized dealer or to Kraus as being defective within the warranty period will be repaired or replaced with a product of equal value at the option of Kraus. This warranty extends to the original owner or end-user, and is not transferable to a subsequent owner.

Restrictions

This warranty does not cover antediluvian, discontinued, or display products, whether such items are purchased at discount outlets, unauthorized dealers, and/or sold on clearance.

This warranty does not cover instances of negligence, misuse, abuse, improper installation, carelessness, accident, hard water or mineral deposits, exposure to corrosive materials, misapplication, damages caused by improper maintenance, alteration of the product, or failure to follow care or installation instructions enclosed with your product. Avoid using abrasive cleaners such as powders, bleach, ammonia, alcohol, or chlorine. Avoid using abrasive pads, steel wool, or wire brushes, as these will damage and wear down the finish.

This warranty does not apply to Products that have not been installed or operated in accordance with instructions supplied by Kraus and all applicable rules, regulations, and legislation pertaining to such installations.

Kraus USA recommends that all Kraus products are installed by fully licensed and insured trade professionals with experience in the installation of bathroom and/or kitchen manufactured goods.

This warranty does not cover labor charges or costs of removal and reinstallation of said product. This warranty does not allow recovery of incidental or consequential damages, such as loss of use, delay, property damage, or other consequential damages, and Kraus accepts no liability for such damages.

(Due to the nature of drain usage, there is no finish warranty on any drain product/including pop-up drains, lavatory drains and kitchen drains)

This warranty does not cover Marine or Outdoor Installation.

Except as otherwise provided above, Kraus makes no warranties, expressed or implied, including warranties of merchantability and fitness for a particular purpose, or compliance with any code.

Shipping charges will be covered for the first (1) year of the warranted replacement part or product (HI, AK, and Puerto Rico shipping charges may apply). International shipping fees are not included.

Commercial Warranty

Kraus extends the above warranty for a period of one (1) year to purchasers of products for industrial, commercial, and business use.

All incidental or consequential damages are specifically excluded. No additional warranties, express or implied are given, including but not limited to, any implied warranty of merchantability or fitness for a particular purpose.

Some states do not allow the exclusion or limitation of incidental or consequential damages, or limitations on how long an implied warranty lasts, so the above limitations or exclusions may not apply to you.

This warranty gives you specific legal rights, and you may also have other rights which vary from state to state.

If you are a homeowner, please contact a Kraus Customer Service Representative at:

Kraus USA, Inc.
12 Harbor Park Drive
Port Washington, NY 11050
Toll-Free : 800-775-0703
Customerservice@kraususa.com

If you are a plumbing contractor or trade professional, please contact a Kraus Pro Representative at:

Kraus USA, Inc.
12 Harbor Park Drive
Port Washington, NY 11050
516-801-8955
Proservice@kraususa.com

If you are an authorized partner, please contact a Partner Support Representative at:

Kraus USA, Inc.
12 Harbor Park Drive
Port Washington, NY 11050
516-801-8954
Partnersupport@kraususa.com

In requesting warranty service, please be ready to provide:

1. Proof of purchase.
2. A description of the problem.

Download the Kraus Care & Maintenance Guide at:

<http://www.kraususa.com/maintenance>

IMPORTANT

Register Your Kraus Product

Activate Your Warranty

Access Premium Customer Support

Get Product Information

REGISTER TODAY

<http://www.kraususa.com/registration>



Kräus[®]
www.kraususa.com

TROUBLE - SHOOTING

If you have followed the instructions carefully and your faucet still does not work properly, take the following corrective steps

PROBLEM	CAUSE	ACTION
Drain is leaking	Washers may be compromised or installed incorrectly	Check washers to make sure they are installed correctly and not cracked

KRAUS LIFETIME LIMITED WARRANTY

Kraus products are manufactured and tested to the highest quality standards by Kraus USA Inc. ("Kraus").

Kraus extends this warranty to the original purchaser for personal household use of the **"Bathroom Accessories"** in their original location. The warranty is non-transferable.

Kraus warrants the structure and finish of the product (**Bathroom Accessories**) to be free from defects in material and workmanship under normal usage for a period of one (1) year. The warranty commences from the initial date of purchase by the owner or trade professional, from an authorized Kraus dealer, through the lifetime of the original owner or end-user.

Any product reported to the authorized dealer or to Kraus as being defective within the warranty period will be repaired or replaced with a product of equal value at the option of Kraus. This warranty extends to the original owner or end-user, and is not transferable to a subsequent owner.

RESTRICTIONS

This warranty does not cover antediluvian, discontinued, or display products, whether such items are purchased at discount outlets, unauthorized dealers, and/or sold on clearance.

This warranty does not cover instances of negligence, misuse, abuse, improper installation, carelessness, accident, hard water or mineral deposits, exposure to corrosive materials, misapplication, damages caused by improper maintenance, alteration of the product, or failure to follow care or installation instructions enclosed with your product. Avoid using abrasive cleaners such as powders, bleach, ammonia, alcohol, or

chlorine. Avoid using abrasive pads, steel wool, or wire brushes, as these will damage and wear down the finish.

This warranty does not apply to Products that have not been installed or operated in accordance with instructions supplied by Kraus and all applicable rules, regulations, and legislation pertaining to such installations.

This warranty does not apply unless the Kraus product is installed by a fully insured and licensed trade professional. Kraus insists that such professionals have experience in the installation of bathroom and kitchen manufactured goods.

This warranty does not cover labor charges or costs of removal and reinstallation of said product. This warranty does not allow recovery of incidental or consequential damages such as loss of use, delay, property damage, or other consequential damages, and Kraus accepts no liability for such damages.

This warranty does not cover Marine or Outdoor Installation.

Except as otherwise provided above, Kraus makes no warranties, expressed or implied, including warranties of merchantability and fitness for a particular purpose, or compliance with any code.

Shipping charges will be covered for the first (1) year of the warranted replacement part or product (HI, AK, and Puerto Rico shipping charges may apply). International shipping fees are not included.

COMMERCIAL WARRANTY

Kraus extends the above warranty for a period of one (1) year to purchasers of products for industrial, commercial and business use.

All incidental or consequential damages are specifically excluded. No additional warranties, express or implied are given, including but not limited to, any implied warranty of merchantability or fitness for a particular purpose.

Some states do not allow the exclusion or limitation of incidental or consequential damages, or limitations on how long an implied warranty lasts, so the above limitations or exclusions may not apply to you.

This warranty gives you specific legal rights, and you may also have other rights which vary from state to state.

If you are a homeowner please contact Kraus Customer Service Representative at:

Kraus USA, Inc.
12 Harbor Park Drive
Port Washington, NY 11050
Toll-free 800-775-0703
Customerservice@kraususa.com

If you are a plumbing contractor or trade professional please contact a Kraus Pro Representative at:

Kraus USA, Inc.
12 Harbor Park Drive
Port Washington, NY 11050
516-801-8955
Proservice@kraususa.com

If you are an Authorized Partner please contact a Partner Support Representative at:

Kraus USA, Inc.
12 Harbor Park Drive
Port Washington, NY 11050
516-801-8954
Partnersupport@kraususa.com

In requesting warranty service, please be ready to provide:

1. Proof of purchase.
2. A description of the problem.

Kräus®

INSTALLATION GUIDE

POP-UP DRAIN PU-20

Thank You For Purchasing Kraus

We would like to take this opportunity to thank you for your business with Kraus USA. It is our sincere hope that you are completely satisfied with your experience. We welcome any questions or comments you may have, and will be glad to assist you in the future.

For more information about Kraus products, please visit our website at:

www.kraususa.com

Please register your new Kraus product at the following web address in order to activate the warranty and receive the full benefit of customer support:

www.kraususa.com/registration

Sincerely,

Kraus Customer Service

Prior to Installation:

Make sure you have all necessary parts by checking the diagram and parts list.

If any part is missing or damaged, please contact Kraus Customer Service at 800-775-0703 for a replacement.

Kräus®

www.kraususa.com

PU-20 DIAGRAM AND PARTS LISTS

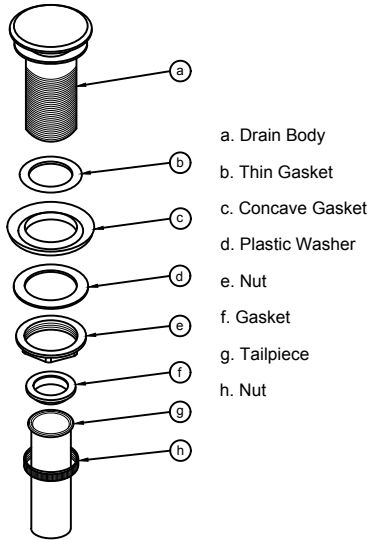

DIMENSIONS

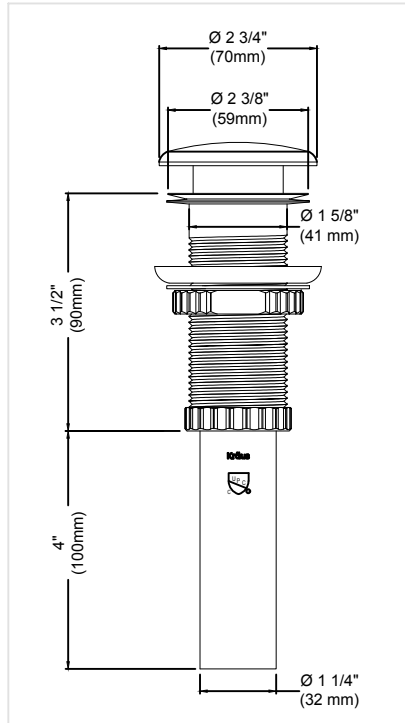

STEP 1

Remove connector (h), tail pipe (g), mounting nut (e), plastic washer (d) and concave washer (c) from drain body (a).

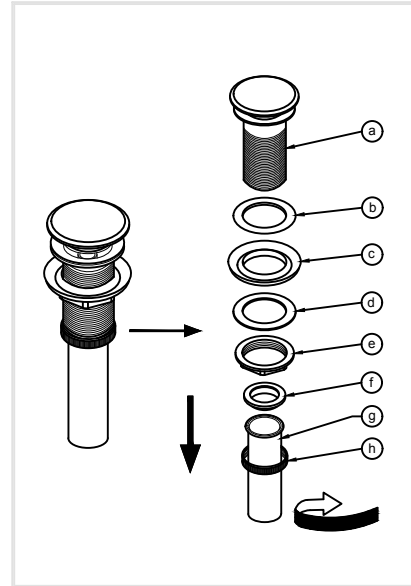

STEP 2

Install drain body (a), with rubber washer (b) attached, into the drain hole. From underneath, attach concave washer (c) (narrow end up), plastic washer (d) and mounting nut (e) to drain body (a).

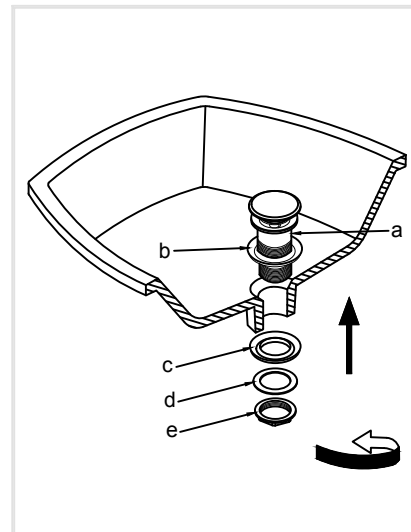

STEP 3

Tighten mounting nut (e) with adjustable wrench until snug. Thread connector (h) with tailpipe (g) attached, onto drain body (a) and hand-tighten.

Installer Tip: Make sure tailpipe washer (f) is installed in tailpipe

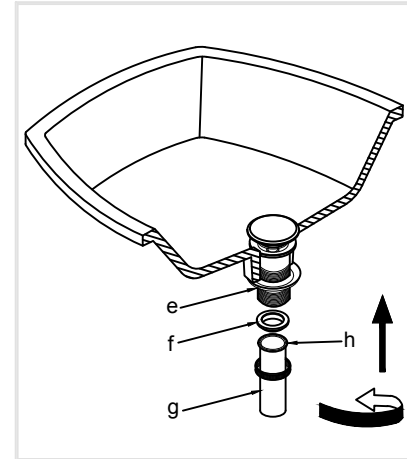

STEP 4

Connect tailpipe (g) to p-trap.

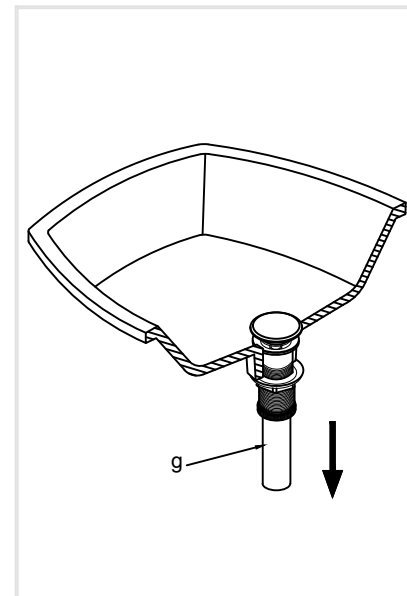

REPLACEMENT PART LIST

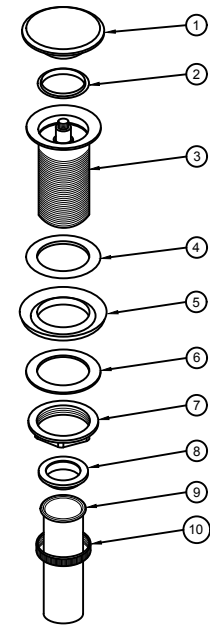

1. Drain Cap
2. Gasket
3. Drain Body
4. Thin Gasket
5. Concave Gasket
6. Plastic Washer
7. Nut
8. Gasket
9. Tailpiece
10. Nut

CARE & MAINTENANCE

* To keep the product clean & shining, follow the steps below:

1. Rinse with clean water & dry with a soft cloth.
2. Do not clean with soaps, acid, polish, abrasives or harsh cleaners.
3. Do not use cloth with a coarse surface.

*This installation manual is subject to change without notice